

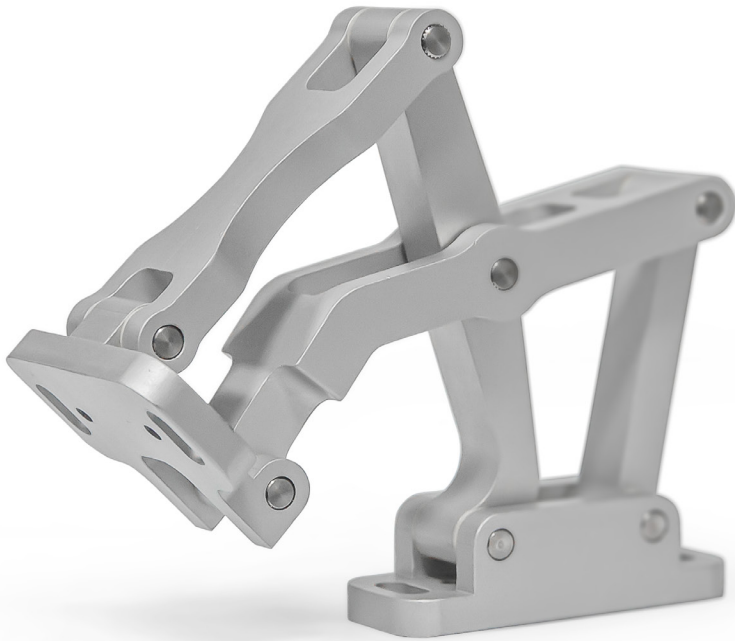

Highlights

Multiple-joint hinges



Standard Parts. **Ganter.**

Contents

Multiple-joint hinges

General notes	→ Page	2
Overview of types	→ Page	3
Design and applications	→ Page	4
Uses and examples of use	→ Page	5

Stainless Steel-Multiple-joint hinges

Stainless Steel-Multiple-joint hinges GN 7231	→ Page	6
Stainless Steel-Multiple-joint hinges GN 7233	→ Page	10
Stainless Steel-Multiple-joint hinges GN 7237	→ Page	14

Accessories for Stainless Steel-Multiple-joint hinges

Stainless Steel-Spacer plates GN 2370	→ Page	22
Stainless Steel-Plates with tapped holes GN 2372	→ Page	23
Stainless Steel-Plates with threaded studs GN 2376	→ Page	24

Aluminum multiple-joint hinges

Multiple-joint hinge GN 7241	→ Page	26
Multiple-joint hinge GN 7243	→ Page	30
Multiple-joint hinge GN 7247	→ Page	34

Accessories for aluminum multiple-joint hinges

Stainless Steel-Spacer plates GN 7247.2	→ Page	38
Stainless Steel-Plates with tapped holes GN 7247.4	→ Page	39
Stainless Steel-Plates with threaded studs GN 7247.6	→ Page	40

Annex

Mounting information	→ Page	42
Technical instructions	→ Page	43
Accessories and special versions	→ Page	44

With the publication of this catalogue, all previous issues become invalid. Technical details are subject to change without notice. The details given herein comply with state of the art engineering at the time of printing. We reserve the right to amend errors and to remove individual articles from the product assortment. The products listed in this catalogue have been developed as standard products with the aim of covering the widest possible spectrum of requirements. We cannot be held liable and responsible for special applications involving extraordinary or unusual uses or requirements concerning our products. Our design department will be pleased to answer questions on certain product properties such as missing tolerance, dimensional details or strength classes. All rights in the catalogue are held by Otto Ganter GmbH & Co. KG. Reprints, also in extracts, are not permitted.

Multiple-joint hinges

General notes

Multiple-joint hinges are a new type of hinge offering freedom of design. Mounted inside the housing to save space and protect against vandalism, they allow an opening angle of up to 180° on flaps, hatches and doors. This ensures that the inside of the housing is optimally accessible. In general, the outside of the housing remains free of attachments that do not match the design or must be avoided entirely due to special requirements, such as ease of cleaning.

Multiple-joint hinges replace existing, conventional hinge solutions while opening up entirely new types of motion since they can do more than directly pivot flaps and doors. The zero-play, self-lubricated multiple-joint mechanism was designed with simulation software and allows a flap to be lifted first on opening and only then pivoted by 180°.

Jointed hinges and cup hinges have long been used in building furniture. These allow similar movements to a certain extent, but the challenges to mounting them in technical environments frequently make them difficult to use. They are also usually designed for low loads.

The fixing angle piece or fastening flange of the multiple-joint hinge is installed on the housing or the door and features slotted holes. Together with the spacer plates available as accessories, the hinges can be adjusted in three planes. This allows them to be used in practically any design. Plates with tapped holes or threaded studs are also available for fast and easy mounting.

Since the development process was focused on creating a design with the most uniform possible gradations of achievable door geometry and load capacity, the hinges are ideal for applications in logistics and vehicle manufacturing in addition to a wide range of industrial applications. The high-quality materials and attractive design open up an even greater range of applications. For example, these hinges are suitable for use in building services equipment as well as in furniture and display cases.

To support more complex applications with specific movement sequences, special versions are available that extend beyond the typical applications involving flaps, hatches and doors. Examples include 4x, 7x or 10x joint mechanisms for corresponding lifting, scissoring or extension systems.

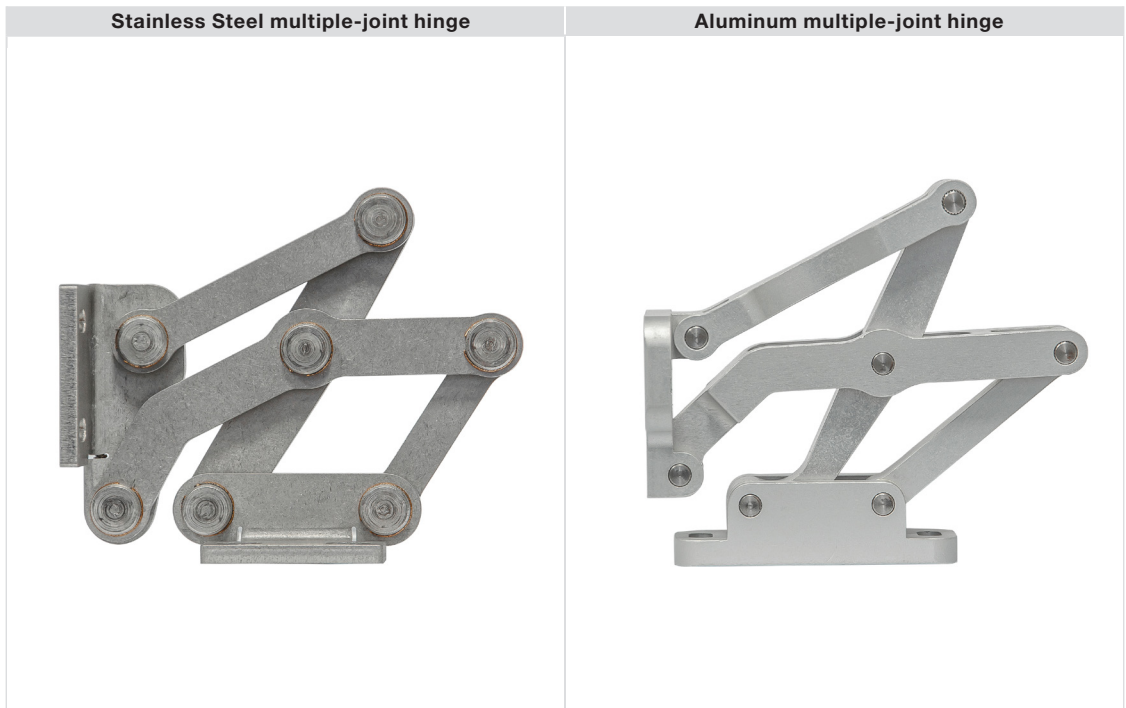

Multiple-joint hinges

Overview of types

Standard	Opening angle	Load capacity per pair in N	max. door or housing thickness (s or b) for design variants insert			Material
			flush	flush	mitered	
GN 7231 Page 6 	90°	$F_A = 175$ $F_R = 750$	$s_{max.} = 60$ $b_{max.} = \infty$	$s_{max.} = \infty$ $b_{max.} = 60$	$s_{max.} = 50$ $b_{max.} = 50$	Stainless Steel
GN 7241 Page 26 	90°	$F_A = 650$ $F_R = 750$	$s_{max.} = 30$ $b_{max.} = \infty$	$s_{max.} = \infty$ $b_{max.} = 30$	$s_{max.} = 30$ $b_{max.} = 30$	Aluminum
GN 7233 Page 10 	120°	$F_A = 175$ $F_R = 750$	$s_{max.} = 50$ $b_{max.} = \infty$	$s_{max.} = \infty$ $b_{max.} = 50$	$s_{max.} = 40$ $b_{max.} = 40$	Stainless Steel
GN 7243 Page 30 	120°	$F_A = 650$ $F_R = 750$	$s_{max.} = 24$ $b_{max.} = \infty$	$s_{max.} = \infty$ $b_{max.} = 24$	$s_{max.} = 20$ $b_{max.} = 20$	Aluminum
GN 7237 Page 14 	180°	$F_A = 175$ $F_R = 750$	$s_{max.} = 25$ $b_{max.} = \infty$	$s_{max.} = \infty$ $b_{max.} = 25$	$s_{max.} = 21$ $b_{max.} = 21$	Stainless Steel
GN 7247 Page 34 	180°	$F_A = 650$ $F_R = 750$	$s_{max.} = 15$ $b_{max.} = \infty$	$s_{max.} = \infty$ $b_{max.} = 15$	$s_{max.} = 11$ $b_{max.} = 11$	Aluminum

Multiple-joint hinges

Design and applications

Design

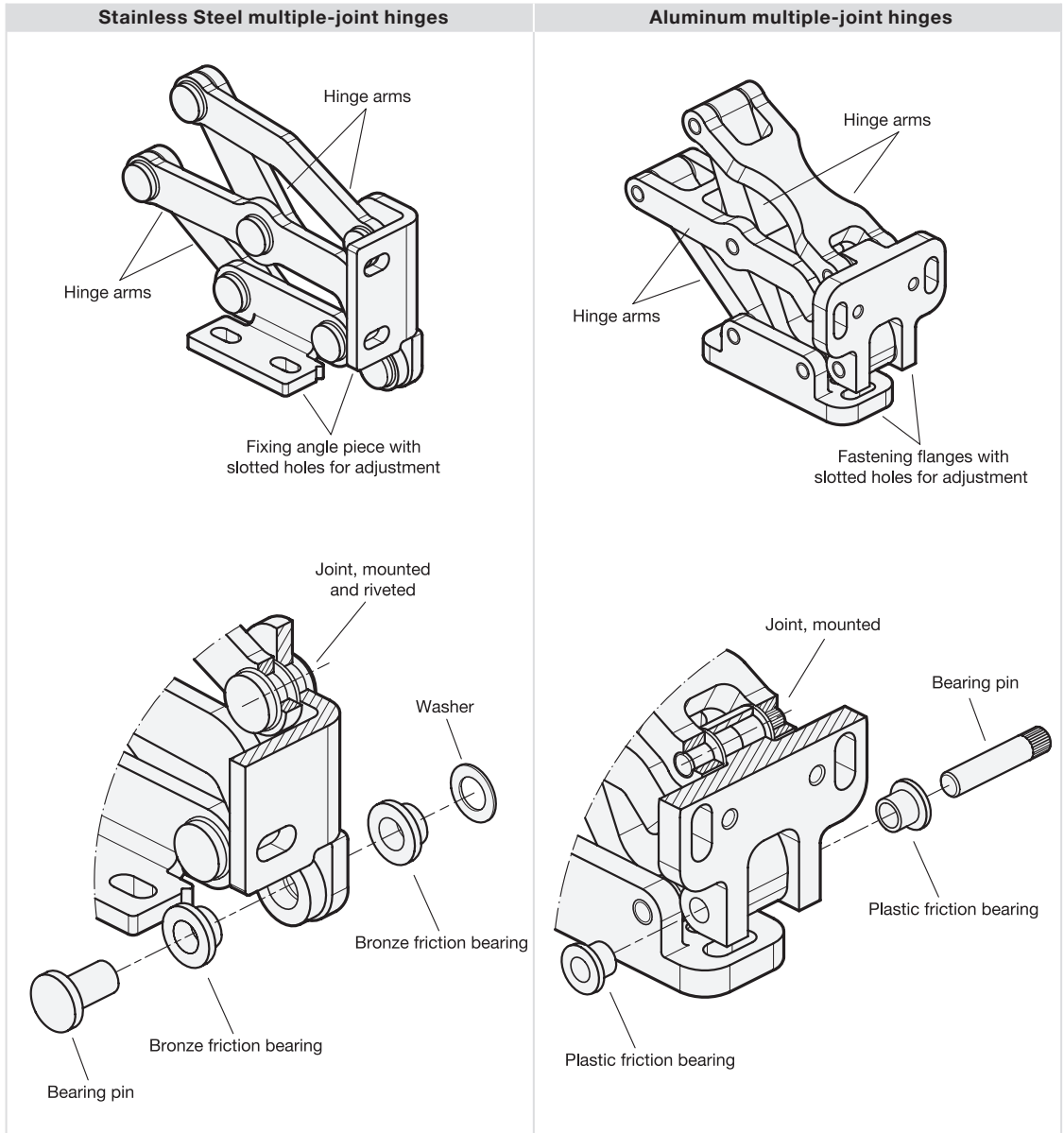

Applications

Stainless Steel-Multiple-joint hinges feature joints arranged in two levels that are very close to each other. This makes them particularly suited for applications involving flaps and hatches.

The joint levels of the aluminum multiple-joint hinges are spaced more widely, making them suitable for use with doors, even heavy ones.

Multiple-joint hinges

Uses and examples of use

Uses and requirements

	Industries	Examples of use	Examples of requirements
Manufacturing	Machine and plant construction	Machine doors, cleaning flaps	Kinematics - Large opening angle - Inside mounting, space-saving, zero play and self-lubricated, reliable, adjustable - Movement sequence as per specification - Lifting with subsequent pivoting - With additional latching or spring elements
	Medical and pharmaceutical industry	Repair and maintenance hatches	
	Chemical and electrical industry	Pivot mechanisms, shelves	
	Logistics and conveyor systems	Safety mechanisms, conveyor hatches, adjusting units and guide systems	
Transport	Bus and rail industry	Luggage hatches, storage compartments, rear and skirting hatches	Design - Surface finish - Refined appearance - Round, convex, concave housing shapes - Inset, flush and mitered - Vandalism-proof, inside mounting, gap-free
	Agricultural and construction machinery	Cabin construction, supplemental equipment, motor covers, front hatches, repair and maintenance openings	
	Ship and yacht building	Exterior hatches, floor hatches, door and maintenance systems	
Architecture	Furniture and display case construction	Interior furnishings and glass enclosures	Safety - Stability and high load capacity - Reliability - Compliance with safety requirements - Avoidance of collisions - High load capacity - Long lifespan - Corrosion resistance
	Building services equipment	Door systems, glass facades, skylights, maintenance and repair shafts, emergency openings, access hatches, stair and floor hatches, fire safety systems	

Examples of use

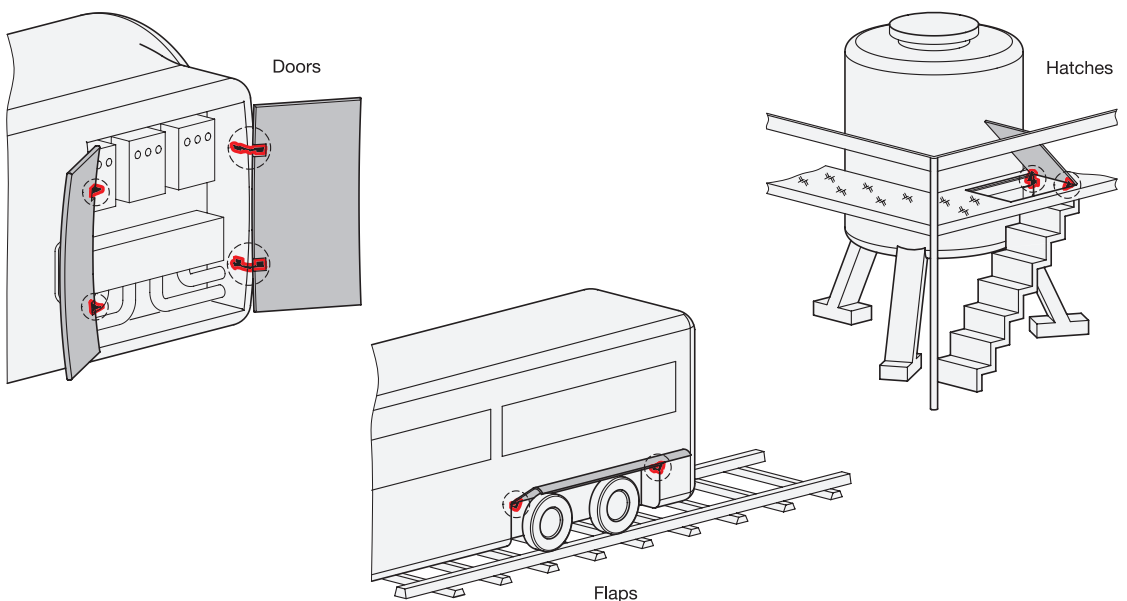

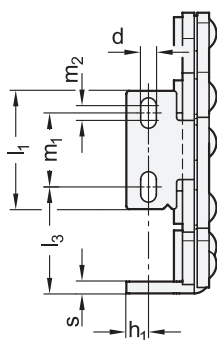

Installation space

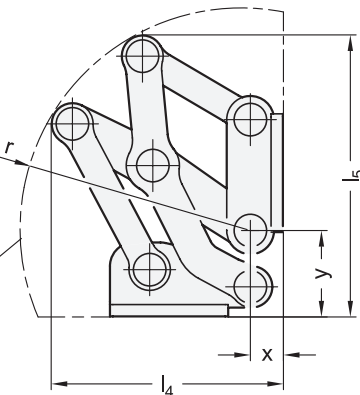

ROSTFREI®
Rost
frei
Inox
Stainless
Steel

3 Type

- L** Fixing angle piece, left
- R** Fixing angle piece, right

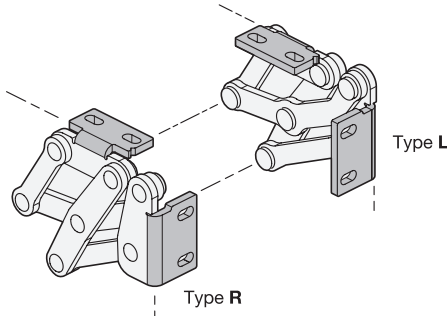
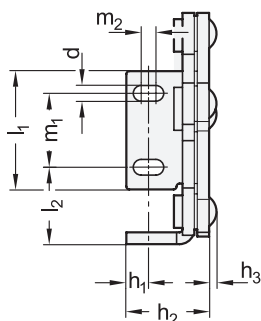

2

l_1	d	h_1	h_2	h_3	l_2	l_3	l_4	l_5	l_6	l_7	l_8	l_9	m_1	m_2	r	s	x	y
40	5,3	7,5	28	2,5	26	36	78	95	23,9	75,8	23,9	85,8	25	5	77,5	4	11	29
50	6,5	10	35	2,5	35	46	101	126	37,2	97,9	37,2	108,6	30	6	97,5	5	19	37
60	8,5	12,5	40	2,5	40	61	126	163	63,9	117,8	63,9	138,6	36	8	127	5	22	47

Specification

- Stainless Steel AISI 304 **NI**
- Friction bearing **MT**
Bronze self lubricated
- *Stainless Steel characteristics*
→ Main Catalogue Page 1489
- **RoHS**

On request

- other materials
- other finishes
- other fixing angle pieces
- other opening angles
- other max. wall thicknesses
- other lifting motion

Information

Stainless Steel-Multiple-joint hinges GN 7231 are installed on the inside of flaps, hatches and doors to save space and ensure protection against vandalism. The hinges have a maximum opening angle of 90°, making them perfect for use with thick doors.

Use of this hinge type leaves housing exteriors free of attachments that do not match the design or that should be avoided entirely in the interests of fast and easy cleaning.

Stainless Steel-Multiple-joint hinges are generally used in pairs, meaning that one L type and one R type are used per opening. For higher loads, e.g. from large flaps or hatches, these can be supplemented with additional hinges of any type.

see also...

- *Stainless Steel-Spacer plates GN 2370* → Page 22
- *Stainless Steel-Plates GN 2372 (with tapped holes)* → Page 23
- *Stainless Steel-Plates GN 2376 (with threaded studs)* → Page 24

How to order

GN 7231-NI-50-R-MT

- 1** Material
- 2** l_1
- 3** Type
- 4** Finish

Installation position - pivot characteristics

The Stainless Steel-Multiple-joint hinges can be installed on the housing with the slots of the fixing angle piece oriented either perpendicular or parallel to the hinge axis. This results in the two pivot characteristics depicted.

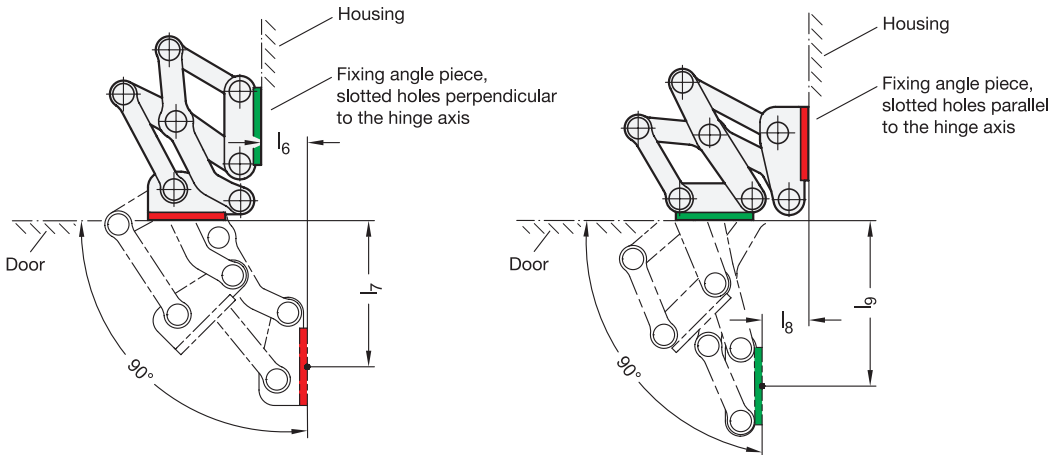

Examples of use

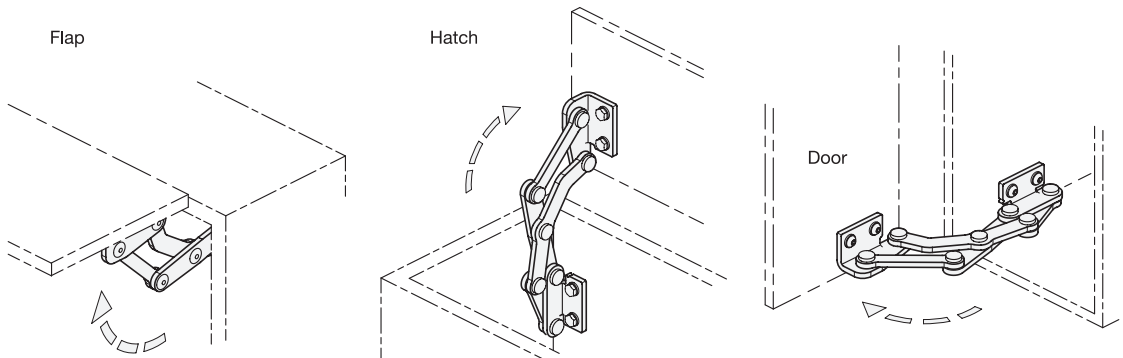

Adjustment and fastening options

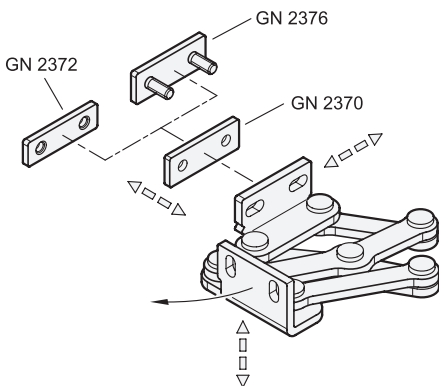

The Stainless Steel-Multiple-joint hinges can be adjusted in three planes during installation. For example, this allows tolerances to be adjusted or the required compressive forces for seals to be established. Two planes can be adjusted via the parallel or perpendicular slots in the fixing angle pieces. In the third plane, position corrections can be made using the Stainless Steel-Spacer plates GN 2370.

Stainless Steel-Plates with tapped holes GN 2372 as well as Stainless Steel-Plates with threaded studs GN 2376 are also available for fastening the hinges. The latter can be welded on or inserted through the wall from the outside and fastened in place. All accessory items are designed for use with both fixing angle pieces.

Design variants

Flaps, hatches and doors can be inset, flush or mitered. The maximum wall thicknesses and bend sizes for sheet metal constructions given below arise from the respective installation type.

1. Fixing angle pieces mounted to the housing with slots perpendicular to the hinge axis:

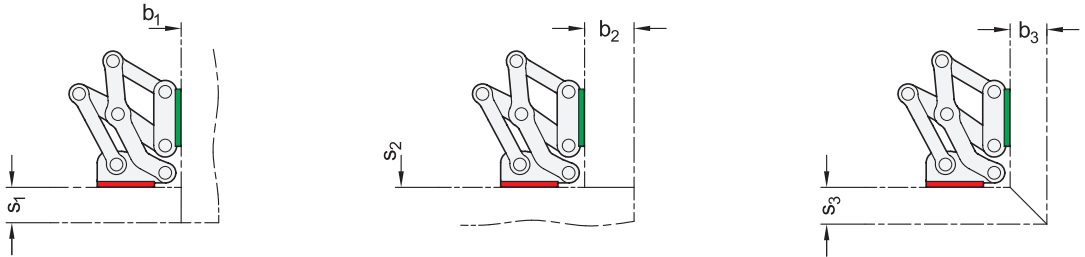

l_1	s_1 max.	b_1	s_2 max.	b_2 max.	s_3 max.	b_3 max.
40	25	1 ... ∞	1 ... ∞	35	26	26
50	30	1 ... ∞	1 ... ∞	45	36	36
60	35	1 ... ∞	1 ... ∞	60	50	50

2. Fixing angle pieces mounted to the housing with slots parallel to the hinge axis:

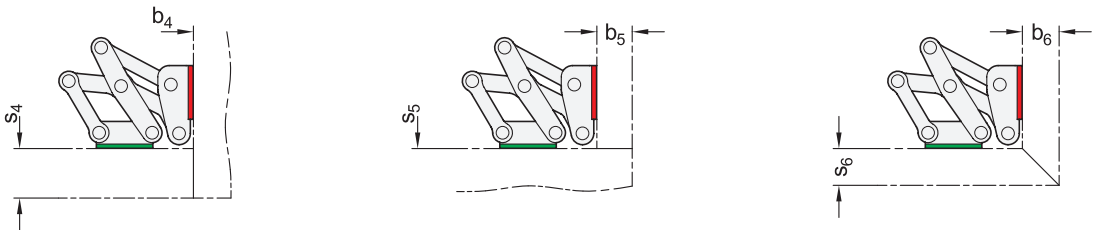

l_1	s_4 max.	b_4 max.	s_5	b_5 max.	s_6 max.	b_6 max.
40	35	1 ... ∞	1 ... ∞	25	26	26
50	45	1 ... ∞	1 ... ∞	30	36	36
60	60	1 ... ∞	1 ... ∞	35	50	50

The design variants shown represent standard installation conditions. If the installation position of the hinge is changed or one of the two wall thickness dimensions is lower than s or b , the maximum achievable dimensions change independently of each other. This makes it possible in some cases to work with larger wall thickness dimensions than those specified with the same hinge size. A simple design check via CAD or a test setup is therefore recommended.



Example of an assembly

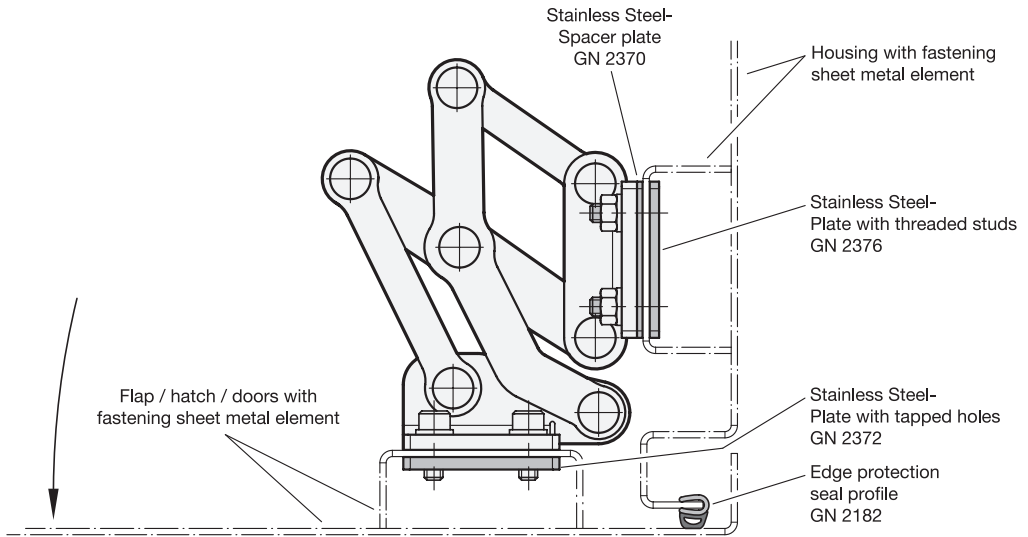

Load capacity

The maximum load of the Stainless Steel-Multiple-joint hinge specified below applies to the standard use cases and serves for orientation in the case of deviating applications. The resulting forces lead to slight elastic deformation, which can be compensated for by means of the adjustment options, if necessary.

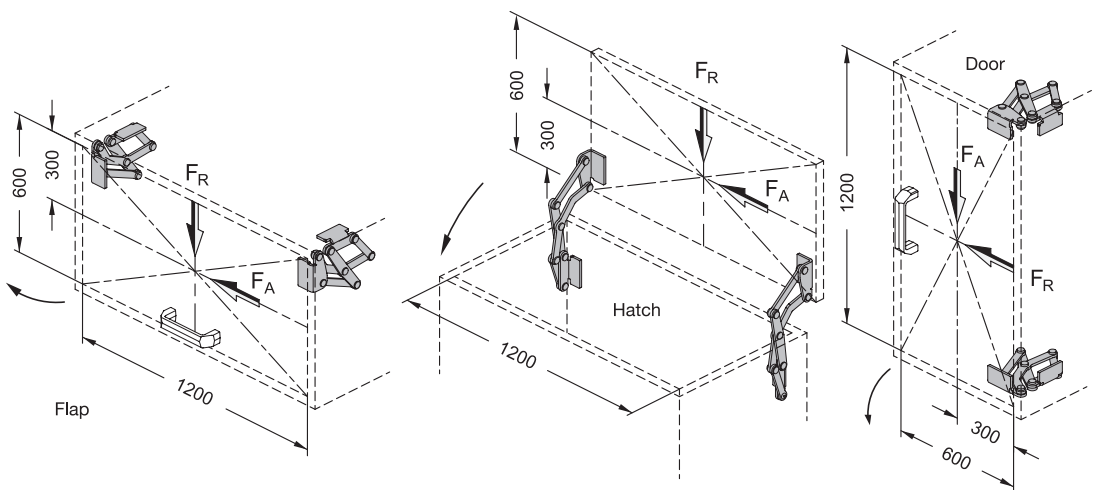

Load capacity per hinge pair in N		
I_1	F_A (axial)	F_R (radial)
40	175	650
50	175	750
60	150	550

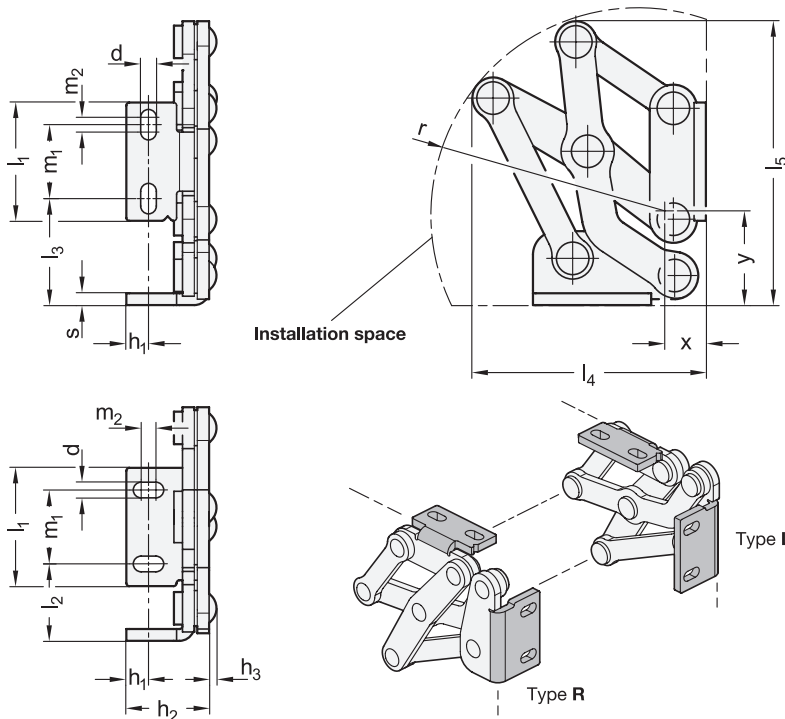

ROSTFREI®
Rost
frei
Inox
Stainless
Steel

3 Type

- L** Fixing angle piece, left
- R** Fixing angle piece, right

2

l_1	d	h_1	h_2	h_3	l_2	l_3	l_4	l_5	l_6	l_7	l_8	l_9	m_1	m_2	r	s	x	y
40	5,3	7,5	28	2,5	26	36	79	96	33,8	65,9	27,9	77,4	25	5	70	4	23	30,5
50	6,5	10	35	2,5	35	46	105	135	79,3	82	2,8	113,3	30	6	105	5	20	37
60	8,5	12,5	40	2,5	40	61	130	169	87,5	107,5	17,4	147,1	36	8	125	5	34	50

Specification

- Stainless Steel AISI 304 **NI**
- Friction bearing **MT**
Bronze self lubricated
- *Stainless Steel characteristics*
→ Main Catalogue Page 1489
- **RoHS**

On request

- other materials
- other finishes
- other fixing angle pieces
- other opening angles
- other max. wall thicknesses
- other lifting motion

Information

Stainless Steel-Multiple-joint hinges GN 7233 are installed on the inside of flaps, hatches and doors to save space and ensure protection against vandalism. The hinges have a maximum opening angle of 120°, allowing for easy accessibility and making them suitable for use with medium-thick doors.

Use of this hinge type leaves housing exteriors free of attachments that do not match the design or that should be avoided entirely in the interests of fast and easy cleaning.

Stainless Steel-Multiple-joint hinges are generally used in pairs, meaning that one L type and one R type are used per opening. For higher loads, e.g. from large flaps or hatches, these can be supplemented with additional hinges of any type.

see also...

- *Stainless Steel-Spacer plates GN 2370* → Page 22
- *Stainless Steel-Plates GN 2372 (with tapped holes)* → Page 23
- *Stainless Steel-Plates GN 2376 (with threaded studs)* → Page 24

How to order	1 Material
1 2 3 4	2 l_1
GN 7233-NI-60-L-MT	3 Type
	4 Finish

Installation position - pivot characteristics

The Stainless Steel-Multiple-joint hinges can be installed on the housing with the slots of the fixing angle piece oriented either perpendicular or parallel to the hinge axis. This results in the two pivot characteristics depicted.

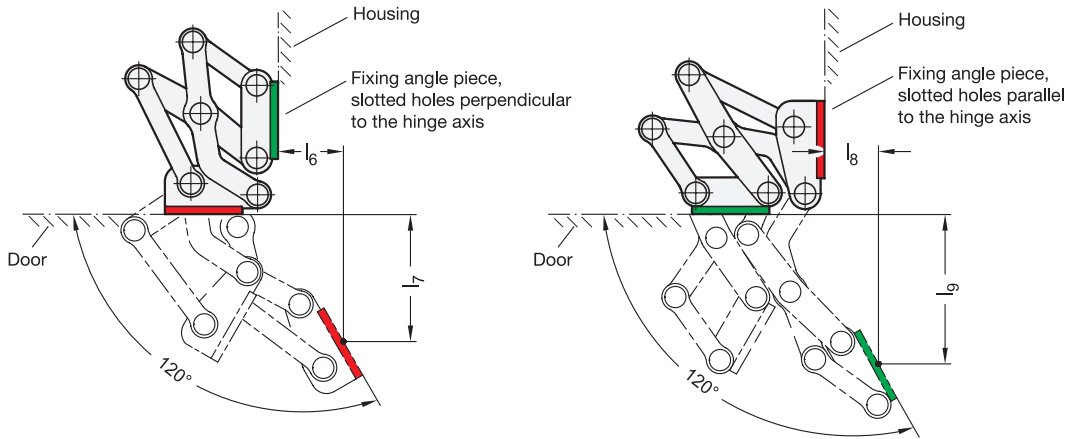

Examples of use

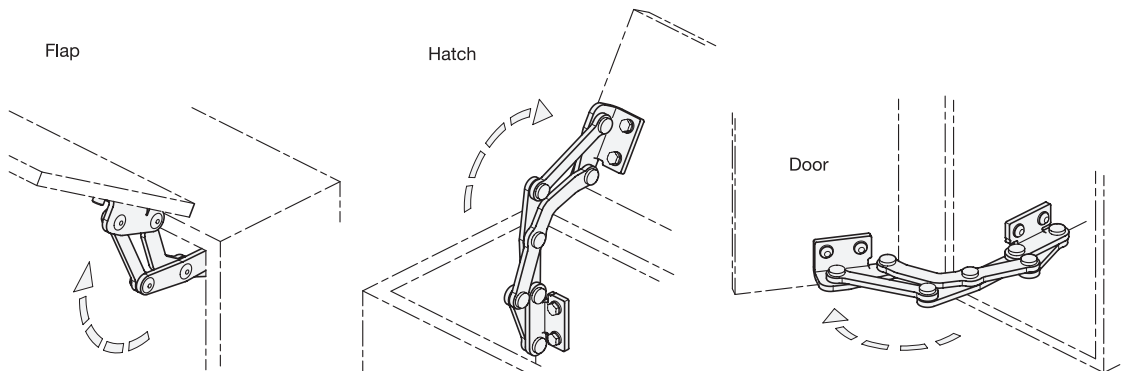

Adjustment and fastening options

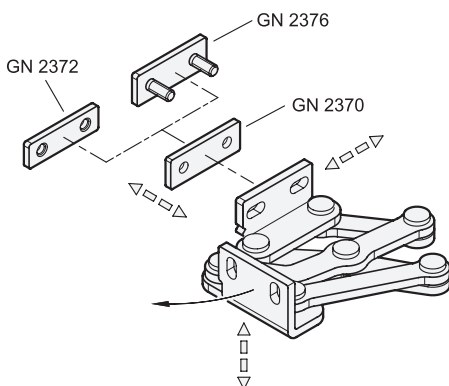

The Stainless Steel-Multiple-joint hinges can be adjusted in three planes during installation. For example, this allows tolerances to be adjusted or the required compressive forces for seals to be established. Two planes can be adjusted via the parallel or perpendicular slots in the fixing angle pieces. In the third plane, position corrections can be made using the Stainless Steel-Spacer plates GN 2370.

Stainless Steel-Plates with tapped holes GN 2372 as well as Stainless Steel-Plates with threaded studs GN 2376 are also available for fastening the hinges. The latter can be welded on or inserted through the wall from the outside and fastened in place. All accessory items are designed for use with both fixing angle pieces.

Design variants

Flaps, hatches and doors can be inset, flush or mitered. The maximum wall thicknesses and bend sizes for sheet metal constructions given below arise from the respective installation type.

1. Fixing angle pieces mounted to the housing with slots perpendicular to the hinge axis:

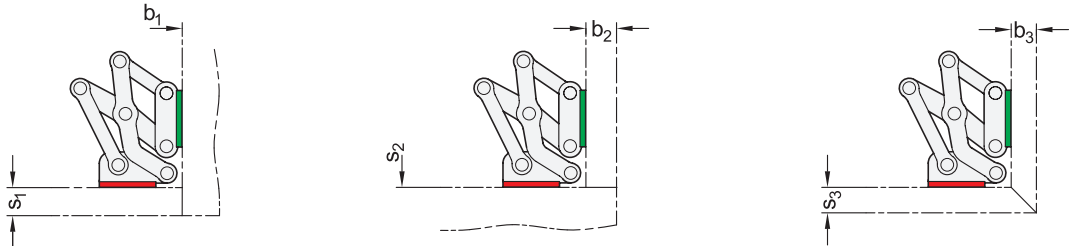

l_1	s_1 max.	b_1	s_2 max.	b_2 max.	s_3 max.	b_3 max.
40	20	1 ... ∞	1 ... ∞	22	18	18
50	25	1 ... ∞	1 ... ∞	38	30	30
60	32	1 ... ∞	1 ... ∞	50	40	40

2. Fixing angle pieces mounted to the housing with slots parallel to the hinge axis:

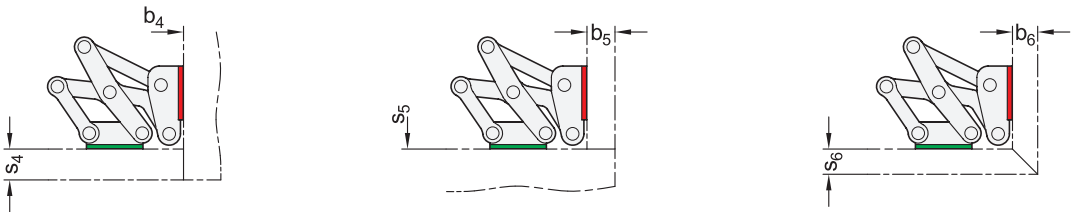

l_1	s_4 max.	b_4 max.	s_5	b_5 max.	s_6 max.	b_6 max.
40	22	1 ... ∞	1 ... ∞	20	18	18
50	38	1 ... ∞	1 ... ∞	25	30	30
60	50	1 ... ∞	1 ... ∞	32	40	40

The design variants shown represent standard installation conditions. If the installation position of the hinge is changed or one of the two wall thickness dimensions is lower than s or b , the maximum achievable dimensions change independently of each other. This makes it possible in some cases to work with larger wall thickness dimensions than those specified with the same hinge size. A simple design check via CAD or a test setup is therefore recommended.



Example of an assembly

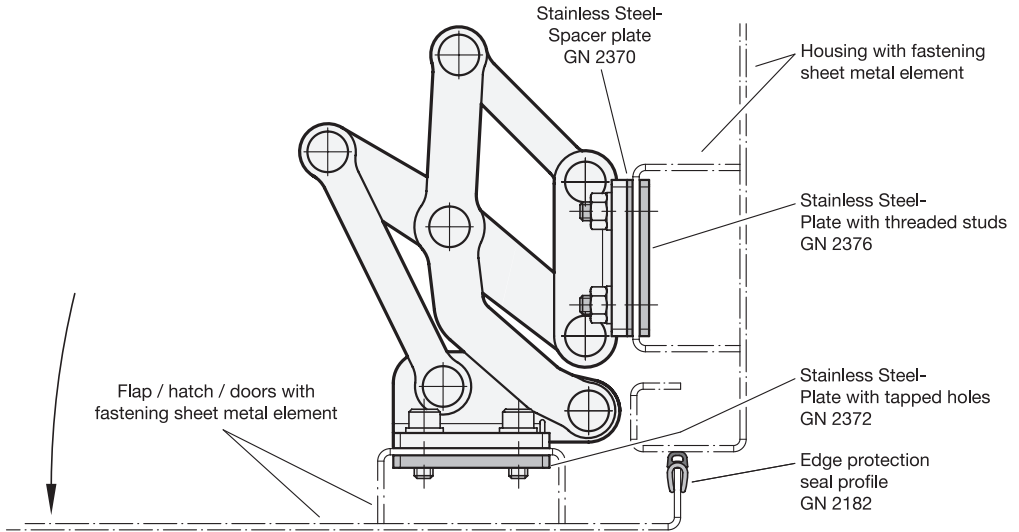

Load capacity

The maximum load of the Stainless Steel-Multiple-joint hinge specified below applies to the standard use cases and serves for orientation in the case of deviating applications. The resulting forces lead to slight elastic deformation, which can be compensated for by means of the adjustment options, if necessary.

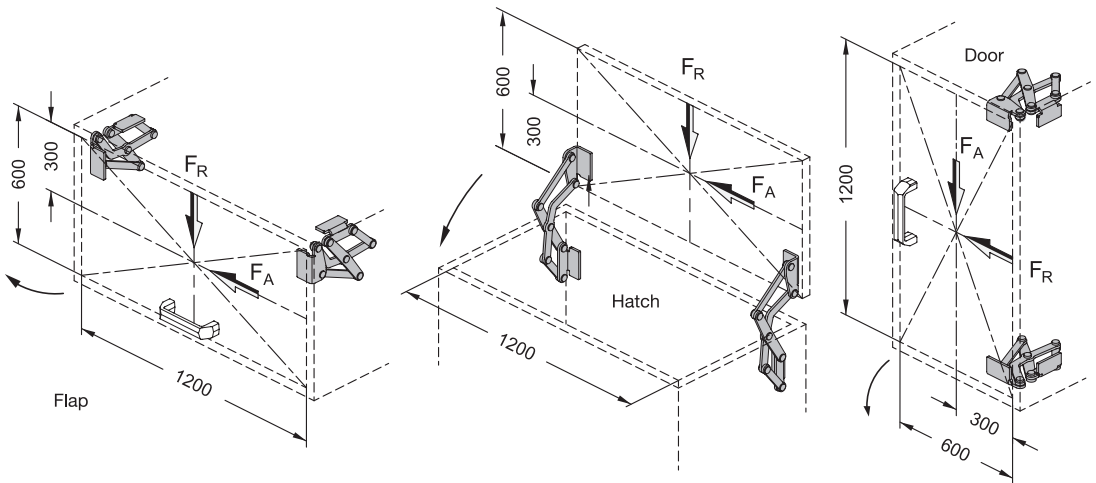

Load capacity per hinge pair in N		
I_1	F_A (axial)	F_R (radial)
40	175	650
50	175	750
60	150	550

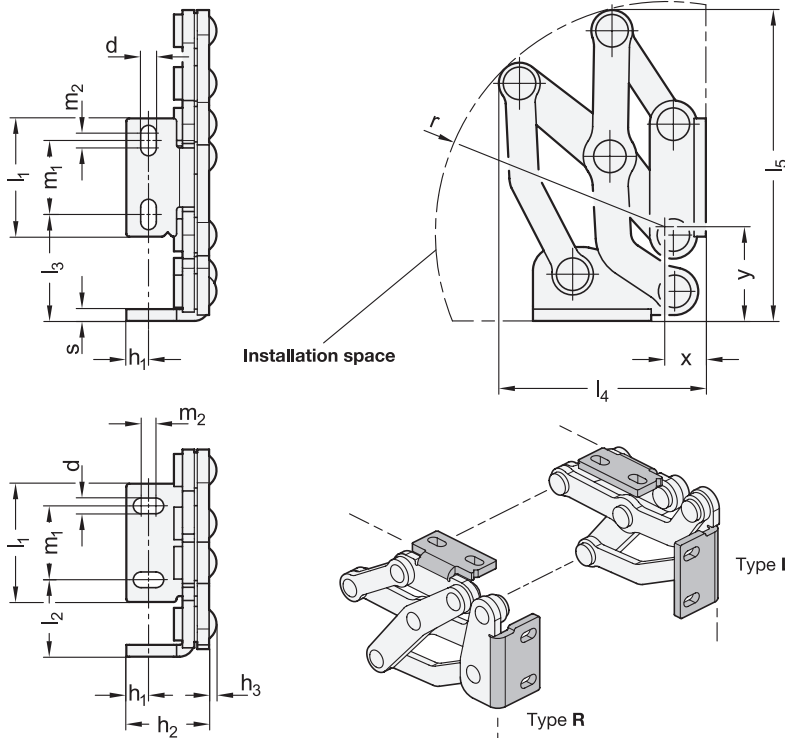

ROSTFREI
Rost
frei
Inox
Stainless
Steel

3 Type

- L** Fixing angle piece, left
- R** Fixing angle piece, right

2

l_1	d	h_1	h_2	h_3	l_2	l_3	l_4	l_5	l_6	l_7	l_8	l_9	m_1	m_2	r	s	x	y
40	5,3	7,5	28	2,5	26	36	70,1	105,2	74,5	27,4	101,9	16	25	5	78,5	4	13	29,5
50	6,5	10	35	2,5	35	46	92,3	140	102,8	39,3	134,7	27,8	30	6	105	5	18	38
60	8,5	12,5	40	2,5	40	61	116,5	179,5	125,2	51,3	172,2	37,2	36	8	137,5	5	19	47

Specification

1

4

- Stainless Steel AISI 304 **NI**
- Friction bearing **MT**
- Bronze self lubricated
- *Stainless Steel characteristics*
→ Main Catalogue Page 1489
- **RoHS**

On request

- other materials
- other finishes
- other fixing angle pieces
- other opening angles
- other max. wall thicknesses
- other lifting motion

Information

Stainless Steel-Multiple-joint hinges GN 7237 are installed on the inside of flaps, hatches and doors to save space and ensure protection against vandalism. The hinges have a maximum opening angle of 180°, which provides optimal accessibility and avoids the blocking of escape routes by open doors, for example.

Use of this hinge type leaves housing exteriors free of attachments that do not match the design or that should be avoided entirely in the interests of fast and easy cleaning.

Stainless Steel-Multiple-joint hinges are generally used in pairs, meaning that one L type and one R type are used per opening. For higher loads, e.g. from large flaps or hatches, these can be supplemented with additional hinges of any type.

siehe auch...

- *Stainless Steel-Spacer plates GN 2370* → Page 22
- *Stainless Steel-Plates GN 2372 (with tapped holes)* → Page 23
- *Stainless Steel-Plates GN 2376 (with threaded studs)* → Page 24

How to order

GN 7237-NI-40-L-MT

- 1** Material
- 2** l_1
- 3** Type
- 4** Finish

Installation position - pivot characteristics

The Stainless Steel-Multiple-joint hinges can be installed on the housing with the slots of the fixing angle piece oriented either perpendicular or parallel to the hinge axis. This results in the two pivot characteristics depicted.

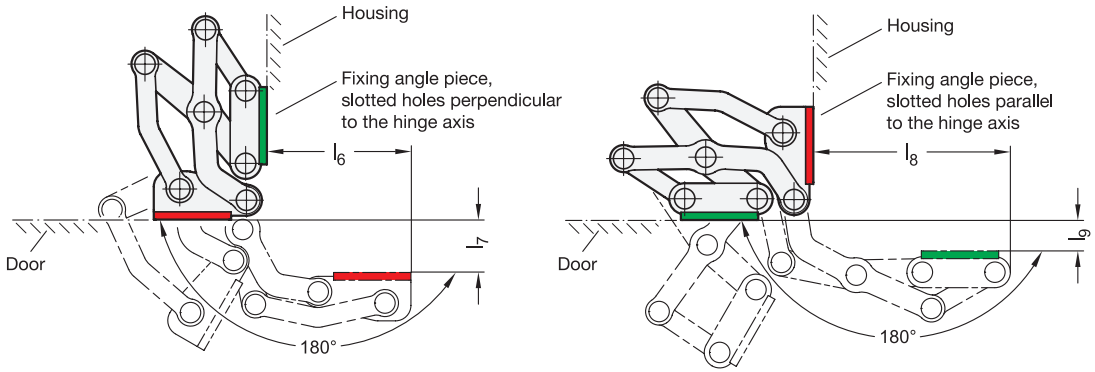

Examples of use

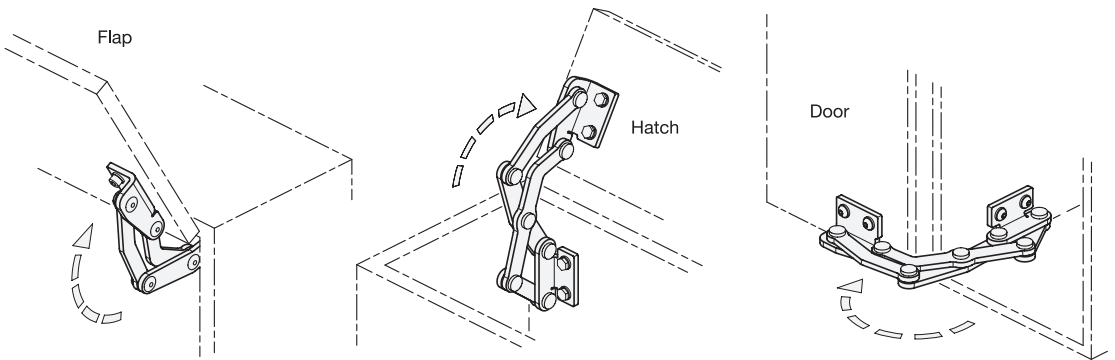

Adjustment and fastening options

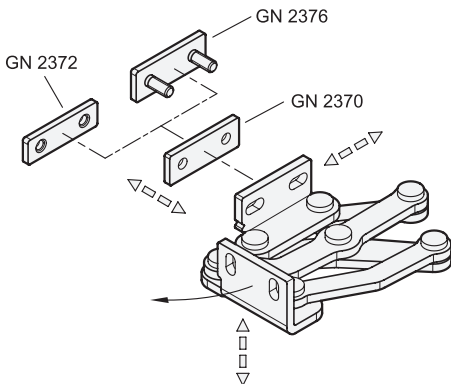

The Stainless Steel-Multiple-joint hinges can be adjusted in three planes during installation. For example, this allows tolerances to be adjusted or the required compressive forces for seals to be established. Two planes can be adjusted via the parallel or perpendicular slots in the fixing angle pieces. In the third plane, position corrections can be made using the Stainless Steel-Spacer plates GN 2370.

Stainless Steel-Plates with tapped holes GN 2372 as well as Stainless Steel-Plates with threaded studs GN 2376 are also available for fastening the hinges. The latter can be welded on or inserted through the wall from the outside and fastened in place. All accessory items are designed for use with both fixing angle pieces.

Design variants

Flaps, hatches and doors can be inset, flush or mitered. The maximum wall thicknesses and bend sizes for sheet metal constructions given below arise from the respective installation type.

1. Fixing angle pieces mounted to the housing with slots perpendicular to the hinge axis:

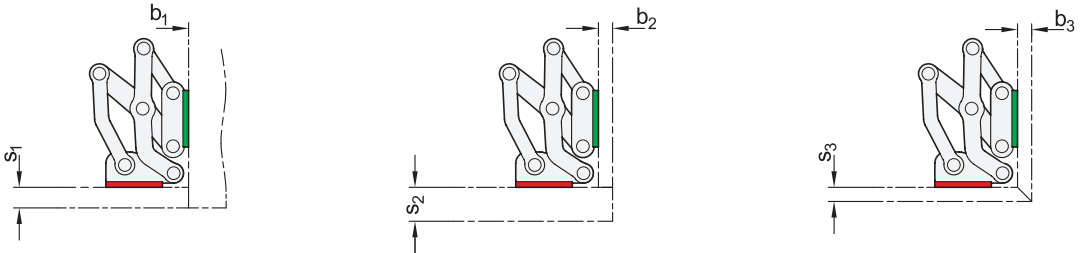

l_1	s_1 max.	b_1	s_2 max.	b_2 max.	s_3 max.	b_3 max.
40	13	1 ... ∞	24	10	10	10
50	19	1 ... ∞	34	17	16	16
60	25	1 ... ∞	44	24	21	21

2. Fixing angle pieces mounted to the housing with slots parallel to the hinge axis:

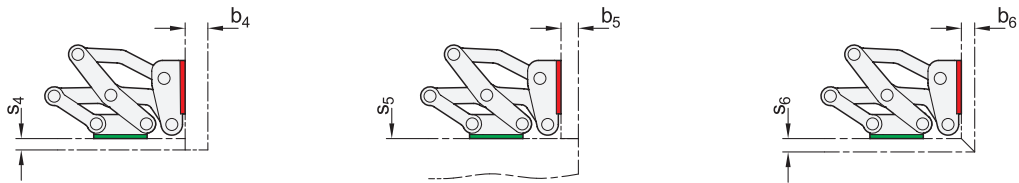

l_1	s_4 max.	b_4 max.	s_5	b_5 max.	s_6 max.	b_6 max.
40	9	27	1 ... ∞	13	10	10
50	17	35	1 ... ∞	19	16	16
60	23	45	1 ... ∞	25	21	21

The design variants shown represent standard installation conditions. If the installation position of the hinge is changed or one of the two wall thickness dimensions is lower than s or b , the maximum achievable dimensions change independently of each other. This makes it possible in some cases to work with larger wall thickness dimensions than those specified with the same hinge size. A simple design check via CAD or a test setup is therefore recommended.



Example of an assembly

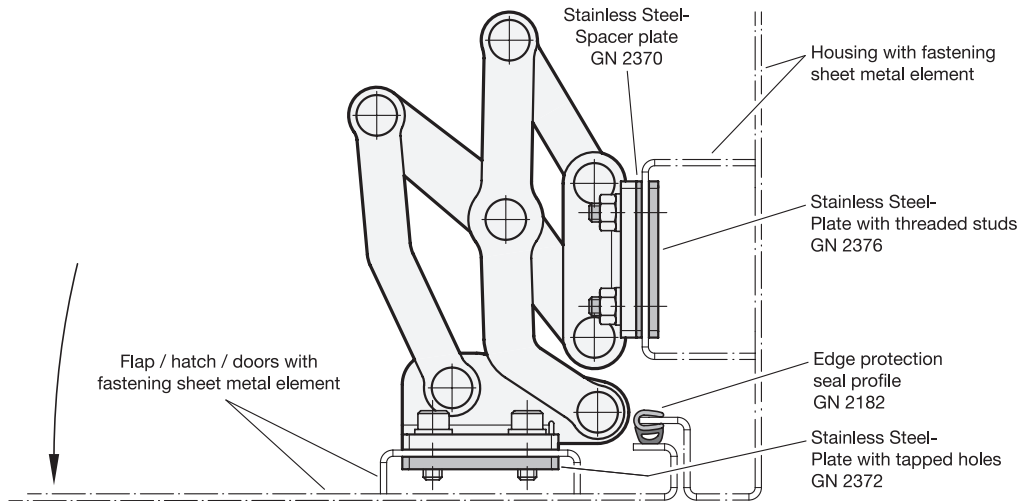

Load capacity

The maximum load of the Stainless Steel-Multiple-joint hinge specified below applies to the standard use cases and serves for orientation in the case of deviating applications. The resulting forces lead to slight elastic deformation, which can be compensated for by means of the adjustment options, if necessary.

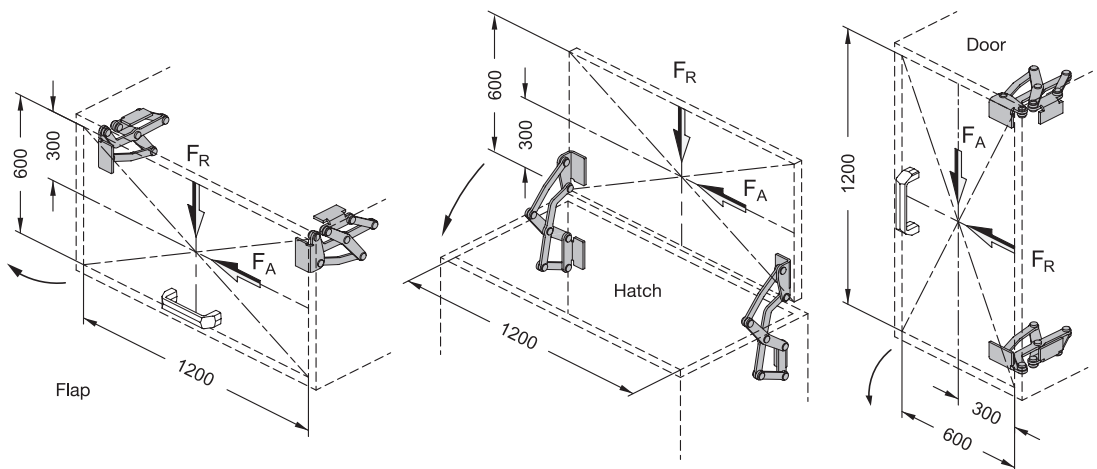

Load capacity per hinge pair in N		
l_1	F_A (axial)	F_R (radial)
40	175	650
50	175	750
60	150	550

Four common sheet metal designs are shown below as examples of the many possibilities. These show the installation of a type L hinge which is also valid for type R. Multiple-joint hinges can be mounted to the housing with the slots on the fixing angle piece either perpendicular or parallel to the hinge axis, resulting in different pivoting characteristics. Recesses within the range of motion of the hinge arms as well as enlarged base elements open up additional design possibilities.

The final function check must be done by the user with CAD or a test setup since various factors, such as the compression of the edge protector sealing profiles, adjustment options and part tolerances, cannot be entirely taken into account.

Example 1 - Flush mounted door with edge protector seal on the housing

Fixing angle piece with slots perpendicular to the hinge axis on the housing

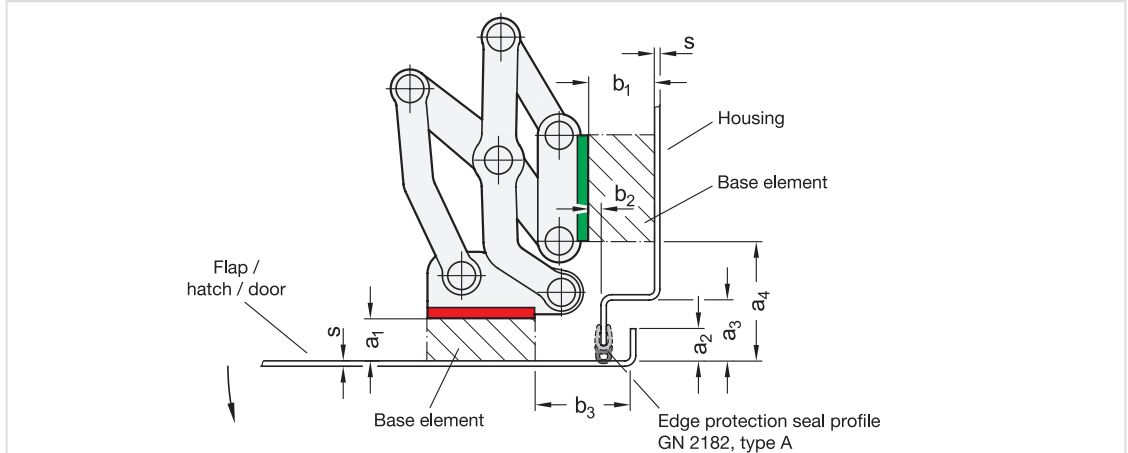

l_1	a_1	a_2	a_3	a_4	b_1	b_2	b_3	s
40	14,5	10	16 ... 35	43	14 ... ∞	0	28,5	1,5
50	19	12	16 ... 48	55	14 ... ∞	0	38	2
60	28	20	22 ... 70	77	17 ... ∞	2	45	2

Fixing angle piece with slots parallel to the hinge axis on the housing

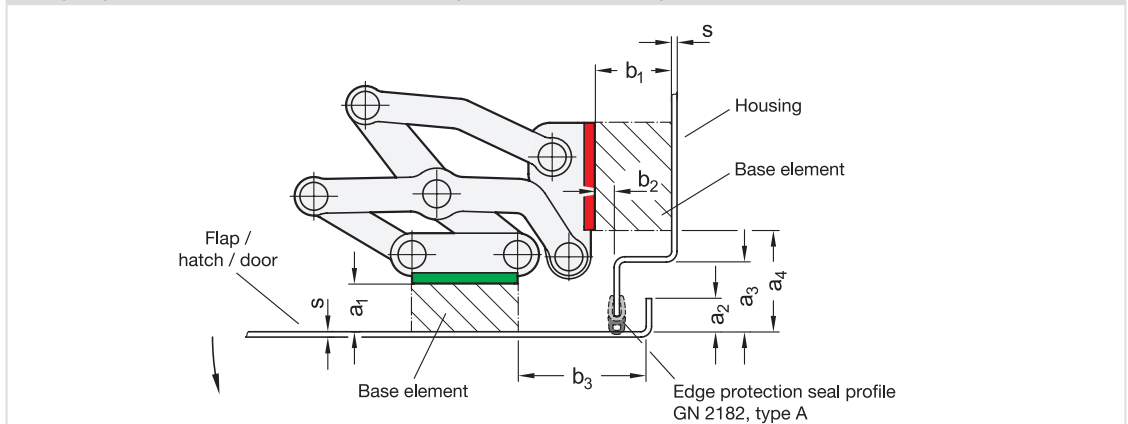

l_1	a_1	a_2	a_3	a_4	b_1	b_2	b_3	s
40	-	-	-	-	-	-	-	-
50	17	10	17 ... 35	42	14 ... ∞	0	50	2
60	25	14	25 ... 46	53	19 ... ∞	2	68	2

Example 2 - Inset door with edge protector seal on the flap / hatch / door

Fixing angle piece with slots perpendicular to the hinge axis on the housing

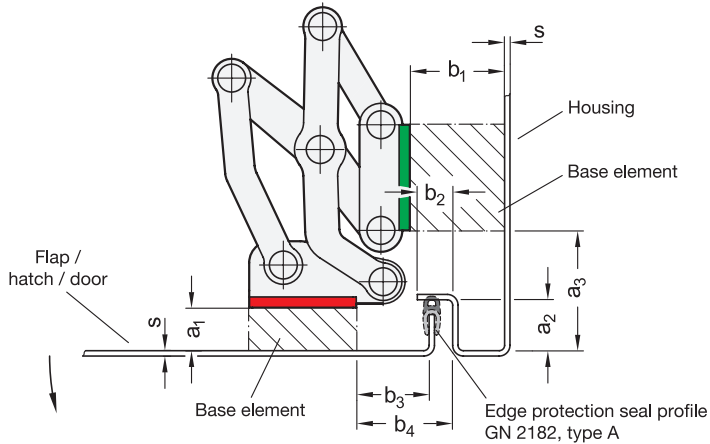

l_1	a_1	a_2	a_3	b_1	b_2	b_3	b_4	s
40	-	-	-	-	-	-	-	-
50	16	19	52	34 ... ∞	12	27	35	2
60	22	27	71	42 ... ∞	14	30	38	2

Fixing angle piece with slots parallel to the hinge axis on the housing

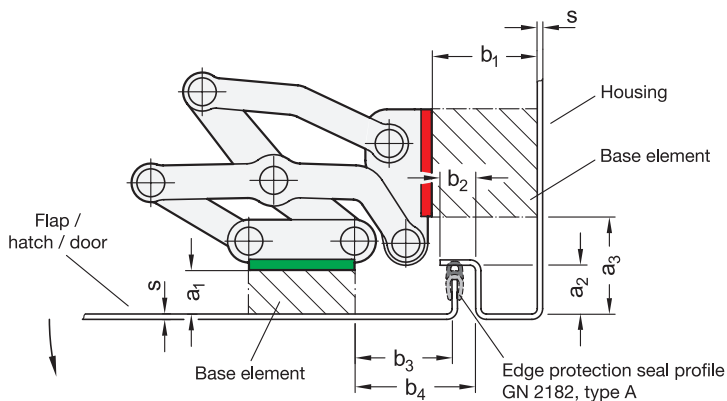

l_1	a_1	a_2	a_3	b_1	b_2	b_3	b_4	s
40	-	-	-	-	-	-	-	-
50	11	16	36	32 ... ∞	12	40	47	2
60	16	21	44	38 ... ∞	14	52	60	2

Example 3 - Inset door with edge protector seal on the housing

Fixing angle piece with slots perpendicular to the hinge axis on the housing

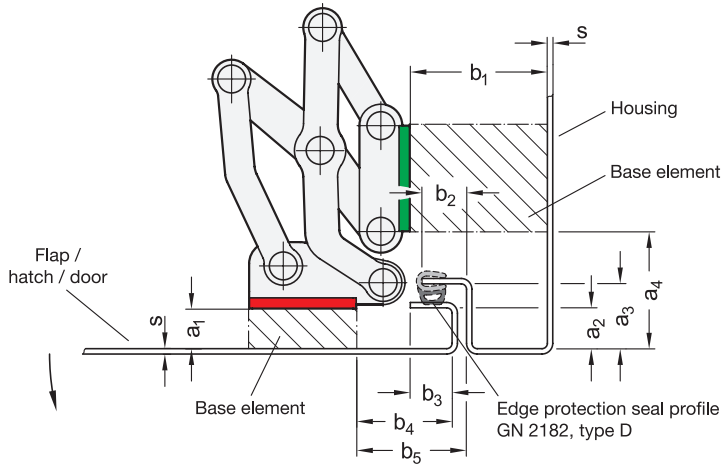

l_1	a_1	a_2	a_3	a_4	b_1	b_2	b_3	b_4	b_5	s
40	-	-	-	-	-	-	-	-	-	-
50	14	14	22	50	43 ... ∞	15	14	38	42	2
60	21	24	32	70	52 ... ∞	16	16	40	44	2

Fixing angle piece with slots parallel to the hinge axis on the housing

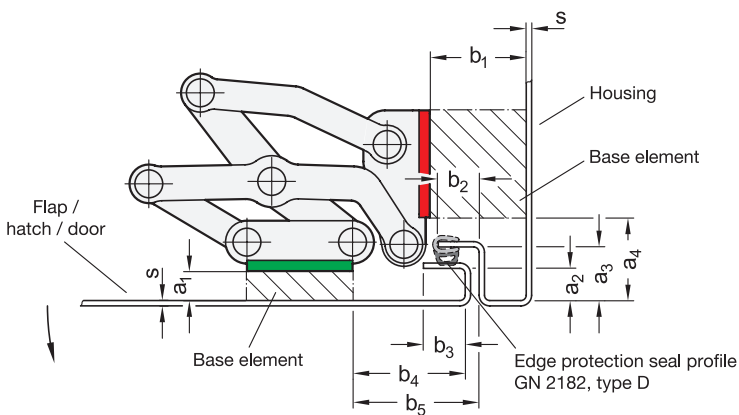

l_1	a_1	a_2	a_3	a_4	b_1	b_2	b_3	b_4	b_5	s
40	-	-	-	-	-	-	-	-	-	-
50	11	12	20	36	40 ... ∞	14	12	47	51	2
60	16	20	28	44	50 ... ∞	16	16	63	67	2

Example 4 - Inset door with foam seal on the flap / hatch / door

Fixing angle piece with slots perpendicular to the hinge axis on the housing

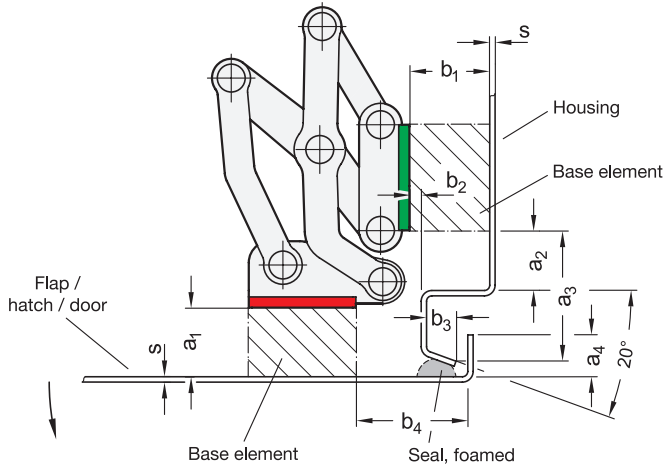

l_1	a_1	a_2	a_3	a_4	b_1	b_2	b_3	b_4	s
40	22	5 ... 25	46,9	10	14 ... ∞	0	8	30	1,5
50	31	5 ... 33	63,3	14	18 ... ∞	2	12	43	2
60	40	5 ... 47	85,1	22	19 ... ∞	2	14	48	2

Fixing angle piece with slots parallel to the hinge axis on the housing

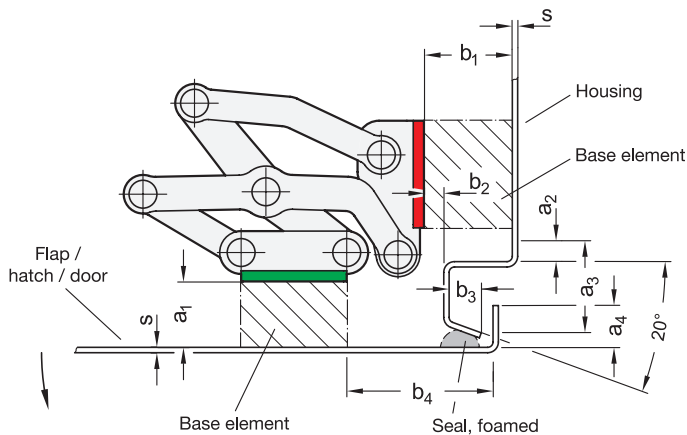

l_1	a_1	a_2	a_3	a_4	b_1	b_2	b_3	b_4	s
40	-	-	-	-	-	-	-	-	-
50	26	5 ... 21	47	12	20 ... ∞	4	11	56	2
60	35	5 ... 24	59	20	24 ... ∞	5	14	73	2

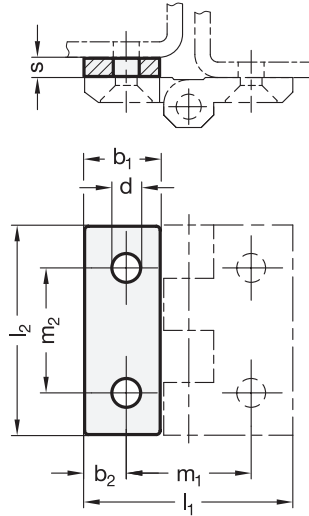

2 3

l ₂	s				b ₁	b ₂	d	l ₁	m ₁	m ₂	Suitable for hinges with hole spacing m ₂								
	1	1,5	3	5							GN 235	GN 337	GN 337.1	GN 437	GN 7231	GN 7233	GN 7237	GN 237	GN 237.1
30	1	1,5	3	5	10,8	6	4	30	18	18	-					x	-	-	
40	1	1,5	3	5	14,5	7,5	5	40	25	25	x					x	-	-	
50	1	1,5	3	5	18	10	6	50	30	30	x					x	x	-	
60	1	1,5	3	5	21,5	12,5	8	60	36	36	x					x	x	x	

Specification

1 4

- Stainless Steel AISI 304 **NI**
matte, ground **MT**
- Stainless Steel characteristics
→ Main Catalogue Page 1489
- RoHS

Information

Tolerances of chamfers, different sheet metal thicknesses or the use of seals could mean that the mounting surfaces of the hinges on the frame and door do not have the desired separating distance.

Stainless Steel-Spacer plates GN 2370 are designed as accessories for multiple families of hinges, and their dimensions allow them to be used as shims either individually or in combination to achieve the desired position or height compensation.

The table includes a number of potential compensation heights which can be accomplished by shimming with one or two spacer plates.

Height compensation	Plate thickness s	Height compensation	Plate thickness s
1	1	4,5	3 + 1,5
1,5	1,5	5	5
2	1 + 1	6	3 + 3
2,5	1 + 1,5	6,5	5 + 1,5
3	3	8	5 + 3
4	3 + 1	10	5 + 5

How to order

1 2 3 4
GN 2370-NI-40-5-MT

- 1 **Material**
- 2 l₂
- 3 s
- 4 **Finish**

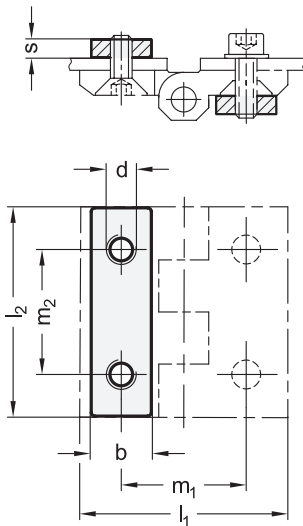

Application example

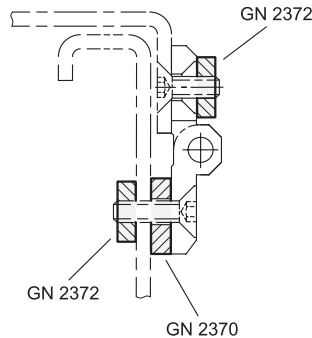

ROESTSTAHL®
Rost
frei
Inox
Stainless
Steel

2

l ₂	b	d	l ₁	m ₁	m ₂	s	Suitable for hinges with hole spacing m ₂								
							GN 235	GN 337	GN 337.1	GN 437	GN 7231	GN 7233	GN 7237	GN 237	GN 237.1
30	9	M 4	30	18	18	3	-						x	-	-
40	12	M 5	40	25	25	3	x						x	-	-
50	15	M 6	50	30	30	4	x						x	x	-
60	18	M 8	60	36	36	4	x						x	x	x

Specification

1

3

- Stainless Steel AISI 304 **NI**
matte, ground **MT**
- Stainless Steel characteristics
→ Main Catalogue Page 1489
- RoHS

Information

Stainless Steel-Plates GN 2372 are designed as accessories for multiple families of hinges with dimensions that make additional threaded holes, nuts and washers unnecessary for mounting.

This eliminates the labor-intensive pre-installation of such parts as well as the need to hold them in place during tightening or loosening. Mounted to the top side of the hinge, the plate offers entirely new assembly options.

see also...

- Stainless Steel-Plates GN 2376 (with threaded studs) → Page 24
- Rubber bumper stops GN 2374 → Main Catalogue Page 962
- Stainless Steel-Spacer plates GN 7247.2 → Page 38
- Stainless Steel-Plates GN 7247.4 (with tapped holes) → Page 39
- Stainless Steel-Plates GN 7247.6 (with threaded studs) → Page 40

How to order

GN 2372-NI-40-MT

- 1 **Material**
- 2 l₂
- 3 **Finish**

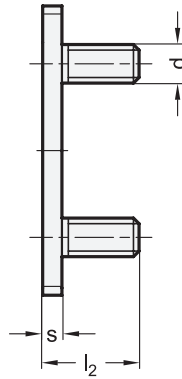
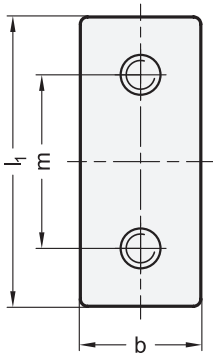

Mounting example

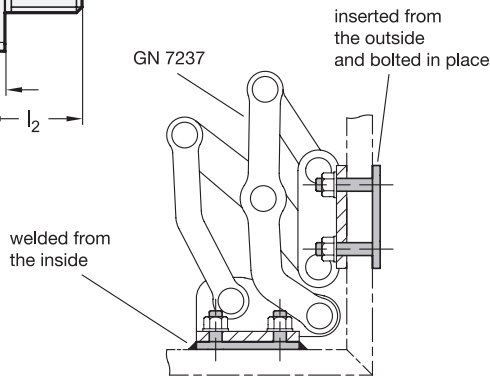

ROSTFREI
Inox
Stainless
Steel

2

3

l ₁	l ₂		b	d	m	s	Suitable for hinges with hole spacing m		
							GN 235	GN 7231 GN 7233 GN 7237	
40	15	25	15	M 5	25	3	x		x
50	20	30	20	M 6	30	3	x		x
60	20	30	25	M 8	36	4	x		x

Specification

1

4

- Stainless Steel AISI 304 matte, ground **NI**
- Threaded studs Stainless Steel AISI 304 pressed-in **MT**
- Stainless Steel characteristics → Main Catalogue Page 1489
- RoHS

On request

- other threaded stud lengths
- other plate sizes
- other plate geometries

Information

Stainless Steel-Plates GN 2376 are designed as accessories for multiple families of hinges. They make additional threaded holes, bolts, nuts and washers unnecessary during installation. This eliminates the labor-intensive pre-installation of such parts as well as the need to hold them in place during tightening or loosening.

The Stainless Steel-Plates are fastened from the outside via through-holes in the housing wall or alternatively by welding to the inside of the wall. This results in effective protection against vandalism, and the out-sides of the housing remain free of attachments that do not match the design or that should be avoided entirely in the interests of easy cleaning.

see also...

- Stainless Steel-Plates GN 2372 (with tapped holes) → Page 23
- Stainless Steel-Spacer plates GN 2370 → Page 22
- Rubber bumper stops GN 2374 → Main Catalogue Page 962

How to order

1 2 3 4
GN 2376-NI-40-15-MT

1	Material
2	l ₁
3	l ₂
4	Finish

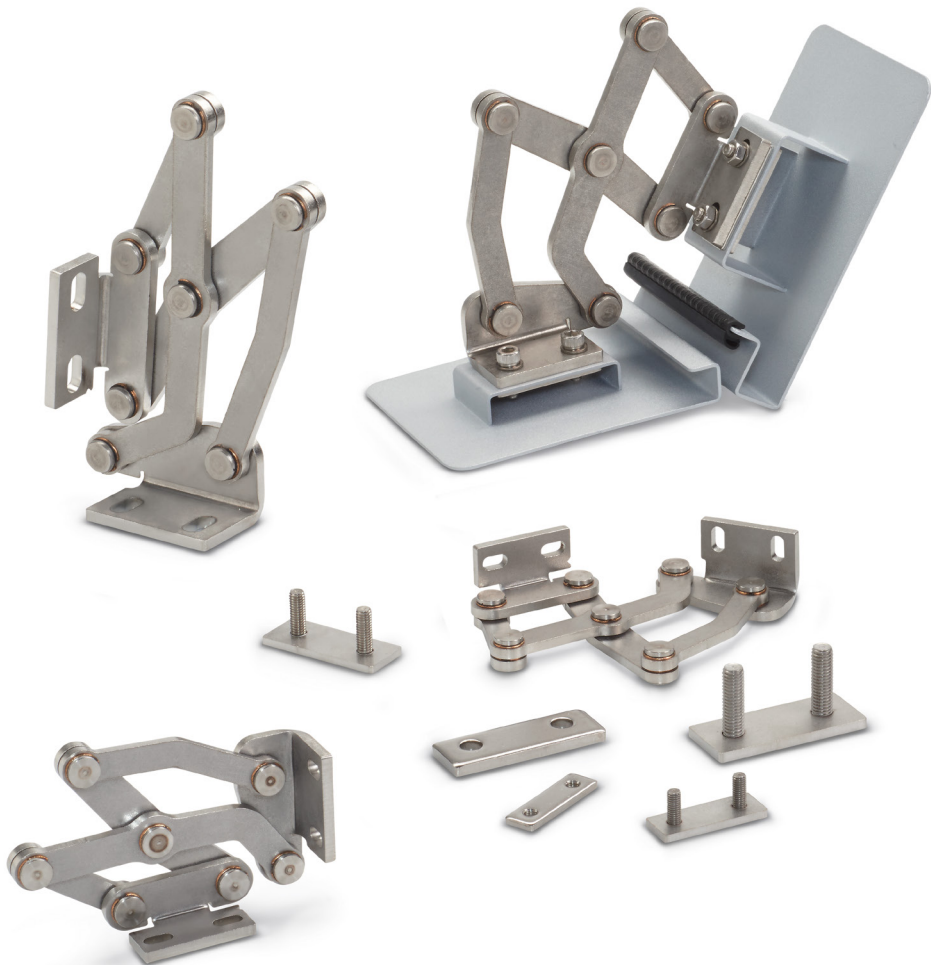

Stainless Steel-Multiple-joint hinges with accessories

GN 7241 Multiple-joint hinge

inside, opening angle 90°

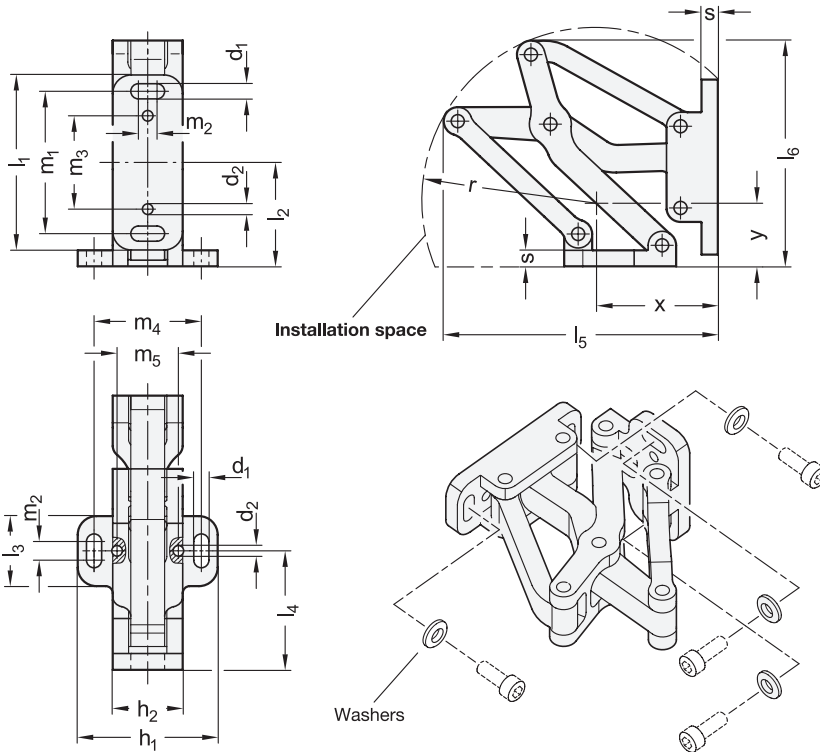

2

l_1	d_1	d_2	h_1	h_2	l_2	l_3	l_4	l_5	l_6	l_7	l_8	l_9	m_1	m_2	m_3	m_4	m_5	r	s	x	y
75	6,5	4	60	30	44,5	30	51	117,5	96,7	13,5	108	101,7	61	8	40	46	28	75	7	52	29

Specification

- Aluminum **AL**
- anodized, natural color **EL**
- Hinge pins / washers
Stainless Steel 304
- Friction bearing
Plastic
- self lubricated
- temperature resistant -40 °C to 90 °C
- Stainless Steel characteristics
→ Main Catalogue Page 1489
- RoHS

On request

- other finishes / colors
- other fastening flanges
- other opening angles
- other max. wall thicknesses
- other lifting motion

Information

The multiple-joint hinges GN 7241 is installed on the inside of doors, flaps and hatches to save space and ensure protection against vandalism. The hinge has a maximum opening angle of 90°, making them perfect for use with thick doors.

Use of this hinge type leaves housing exteriors free of attachments that do not match the design or that should be avoided entirely in the interests of fast and easy cleaning.

Multiple-joint hinges are generally used in pairs. For higher loads, e.g. from large doors, these can be supplemented with additional hinges. Four reinforced washers are supplied, which can be used with fastening screws of thread size M6.

see also...

- Stainless Steel-Spacer plates GN 7247.2 → Page 38
- Stainless Steel-Plates GN 7247.4 (with tapped holes) → Page 39
- Stainless Steel-Plates GN 7247.6 (with threaded studs) → Page 40

How to order

GN 7241-AL-75-EL

1	Material
2	l_1
3	Finish / Color

Installation position - pivot characteristics

The multiple-joint hinges can be installed to the housing with the slots on the fastening flanges either parallel or perpendicular to the hinge axis. This results in the two pivot characteristics depicted.

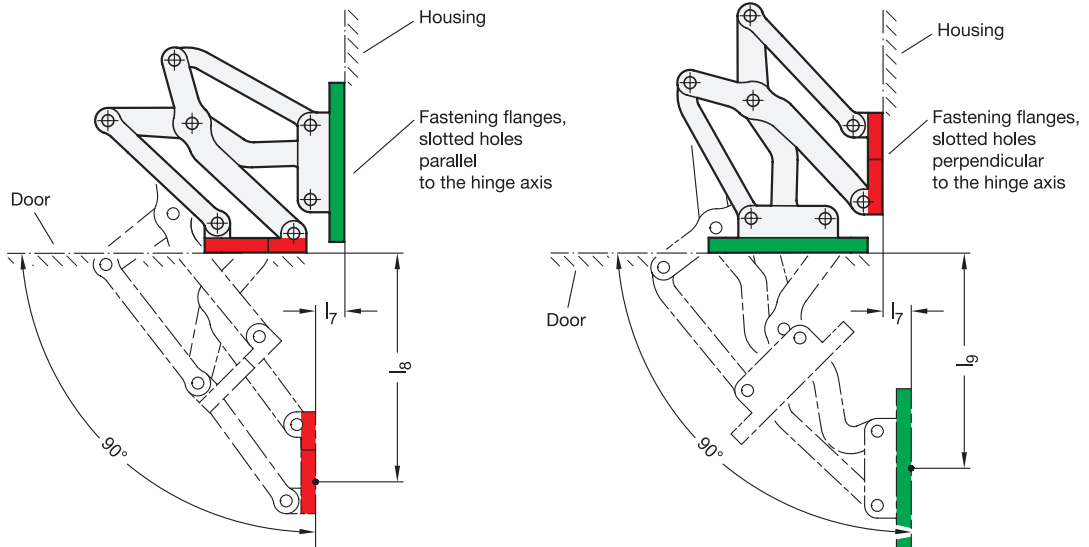

Examples of use

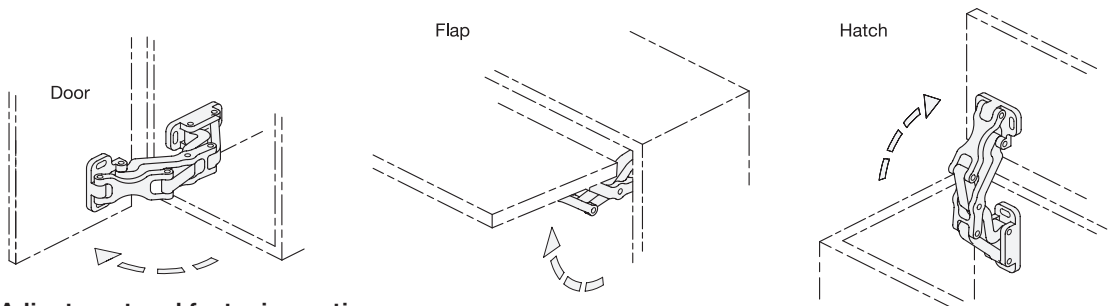

Adjustment and fastening options

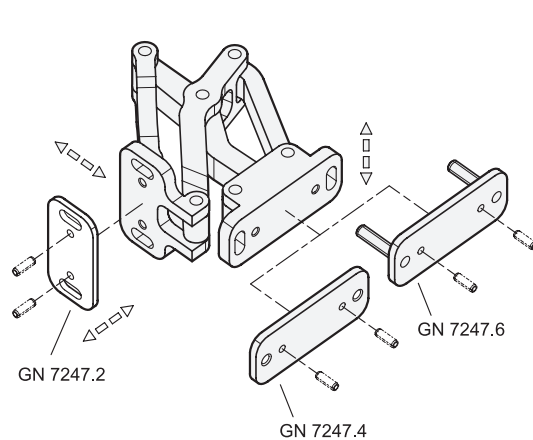

The multiple-joint hinges can be adjusted in three planes during installation. For example, this allows adjustment for tolerances or establishing of required compressive forces for seals. Two planes can be adjusted via parallel or perpendicular slots in the fastening flanges. In the third plane, position corrections can be made using the Stainless Steel-Spacer plates GN 7247.2. Stainless Steel-Plates with tapped holes GN 7247.4 as well as Stainless Steel-Plates with threaded studs GN 7247.6 are also available for fastening the hinges. The latter can be welded on or inserted through the wall from the outside and fastened in place. The holes d_2 receive tensioning or positioning pins, making it easy to position the hinge. This also prevents unintended turning or slipping under load. The pins cannot be removed for subsequent adjustment.

Design variants

Doors, flaps and hatches can be inset, flush or mitered. The maximum wall thicknesses and bend sizes for sheet metal constructions given below arise from the respective installation type.

1. Fastening flange mounted to the housing with slots parallel to the hinge axis:

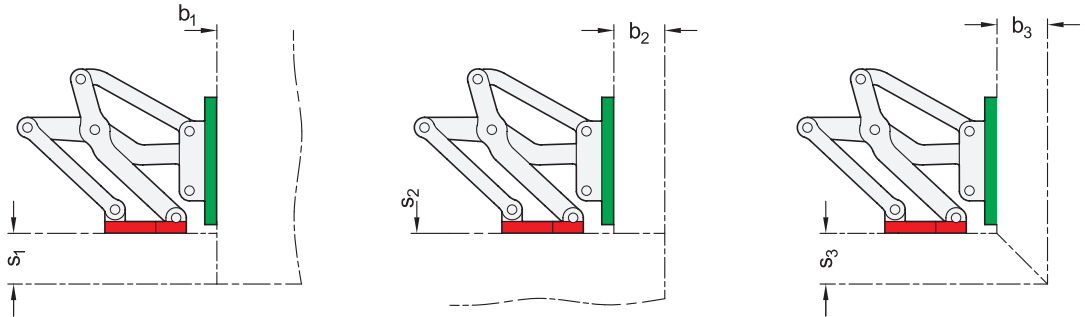

l_1	$s_1 \text{ max.}$	b_1	s_2	$b_2 \text{ max.}$	$s_3 \text{ max.}$	$b_3 \text{ max.}$
75	30	1 ... ∞	1 ... ∞	30	30	30

2. Fastening flange mounted to the housing with slots perpendicular to the hinge axis:

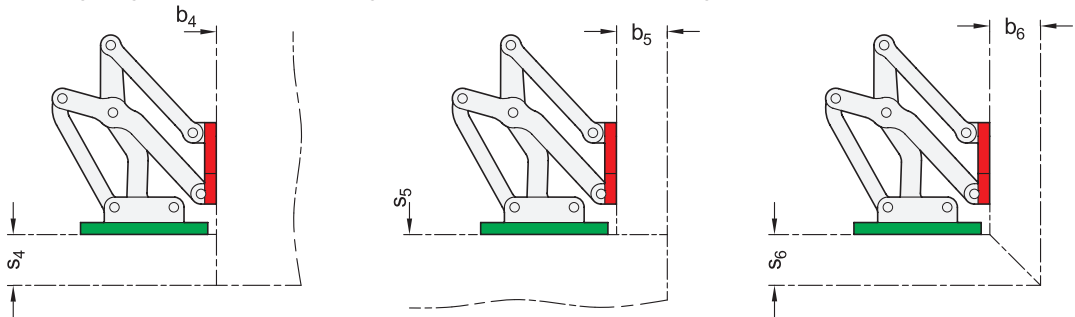

l_1	$s_4 \text{ max.}$	b_4	s_5	$b_5 \text{ max.}$	$s_6 \text{ max.}$	$b_6 \text{ max.}$
75	30	1 ... ∞	1 ... ∞	30	30	30

The design variants shown represent standard installation conditions. If the installation position of the hinge is changed or one of the two wall thickness dimensions is lower than s or b , the maximum achievable dimensions change independently of each other. This makes it possible in some cases to work with larger wall thickness dimensions than those specified with the same hinge size. A simple design check via CAD or a test setup is therefore recommended.



Example of an assembly

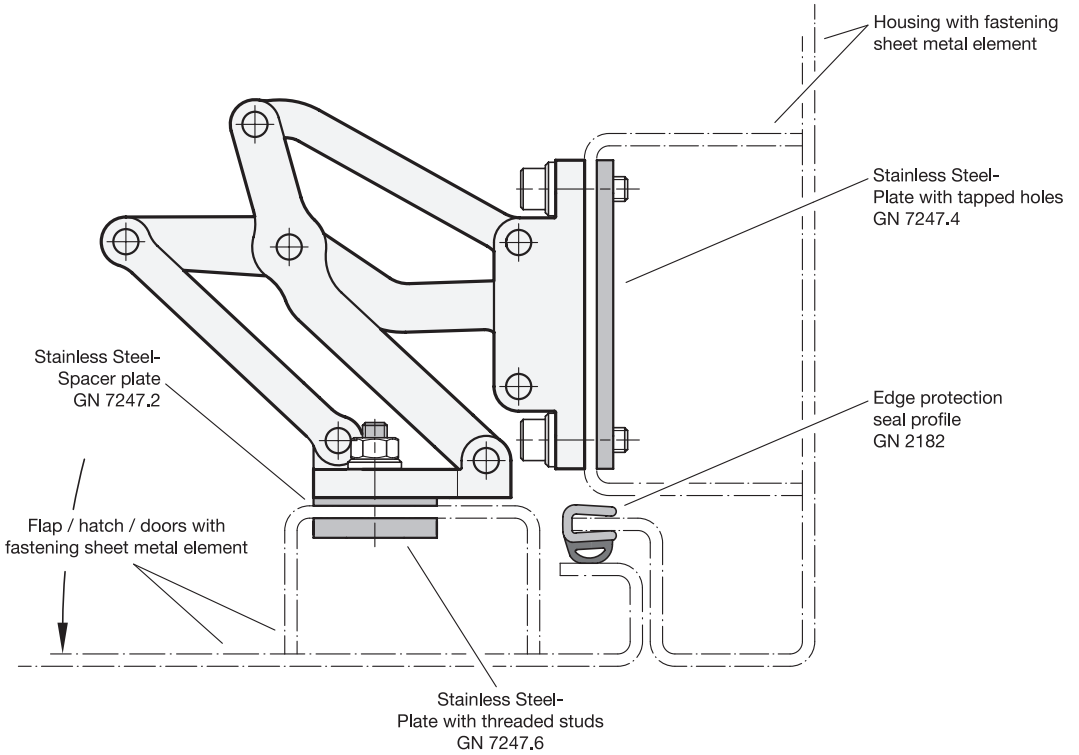

Load capacity

The maximum load of the multiple-joint hinge specified below applies to the standard use cases and serves for orientation in the case of deviating applications. The resulting forces lead to slight elastic deformation, which can be compensated for by means of the adjustment options, if necessary.

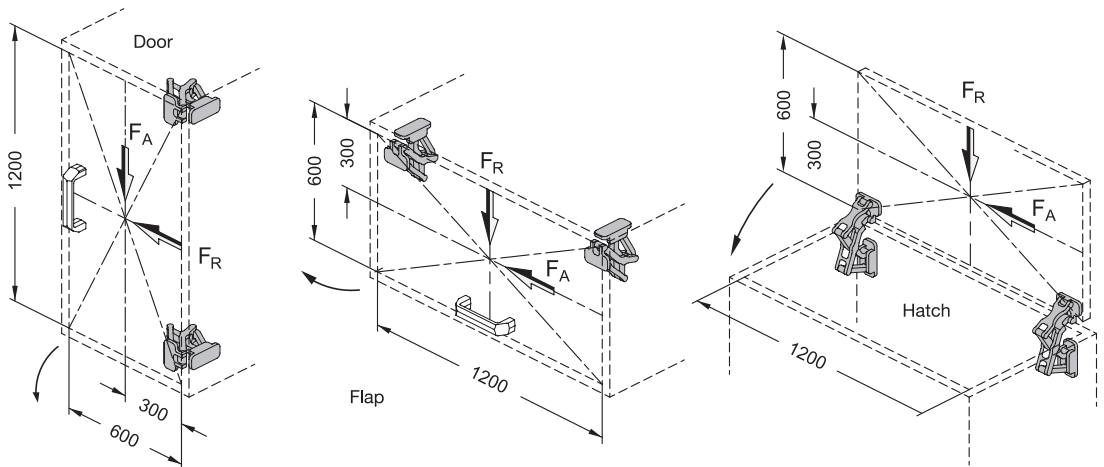

Load capacity per hinge pair in N		
I_1	F_A (axial)	F_R (radial)
75	650	750

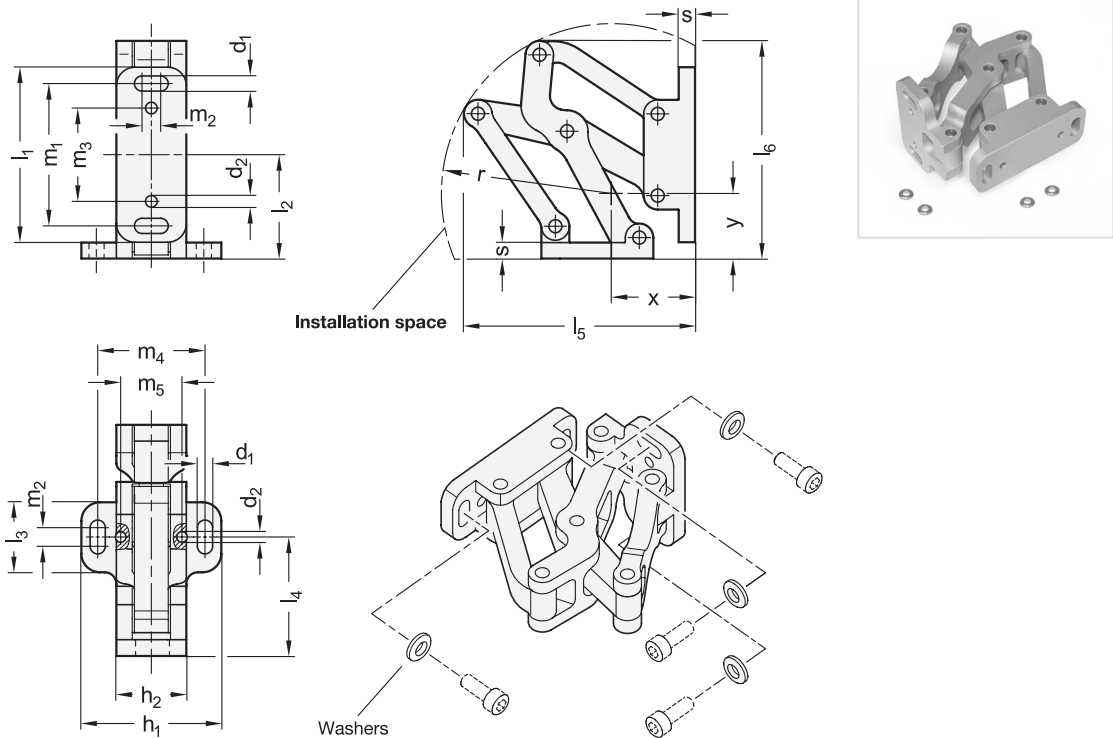

l_1	d_1	d_2	h_1	h_2	l_2	l_3	l_4	l_5	l_6	l_7	l_8	l_9	l_{10}	m_1	m_2	m_3	m_4	m_5	r	s	x	z
75	6,5	4	60	30	44,5	30	51	99	93,3	24	80,4	41,7	69,3	61	8	40	46	28	73	7	36	28

Specification



- Aluminum **AL**
anodized, natural color **EL**
- Hinge pins / washers
Stainless Steel 304
- Friction bearing
Plastic
- self lubricated
- temperature resistant -40 °C to 90 °C
- Stainless Steel characteristics
→ Main Catalogue Page 1489
- RoHS

On request

- other finishes / colors
- other fastening flanges
- other opening angles
- other max. wall thicknesses
- other lifting motion

Information

The multiple-joint hinge GN 7243 is installed on the inside of doors, flaps and hatches to save space and ensure protection against vandalism. The hinge has a maximum opening angle of 120°, allowing for easy accessibility and making them suitable for use with medium-thick doors.

Use of this hinge type leaves housing exteriors free of attachments that do not match the design or that should be avoided entirely in the interests of fast and easy cleaning.

Multiple-joint hinges are generally used in pairs. For higher loads, e.g. from large doors, these can be supplemented with additional hinges. Four reinforced washers are supplied, which can be used with fastening screws of thread size M6.

see also...

- Stainless Steel-Spacer plates GN 7247.2 → Page 38
- Stainless Steel-Plates GN 7247.4 (with tapped holes) → Page 39
- Stainless Steel-Plates GN 7247.6 (with threaded studs) → Page 40

How to order

GN 7243-AL-75-EL

1	Material
2	l_1
3	Finish / Color

Installation position - pivot characteristics

The multiple-joint hinges can be installed to the housing with the slots on the fastening flanges either parallel or perpendicular to the hinge axis. This results in the two pivot characteristics depicted.

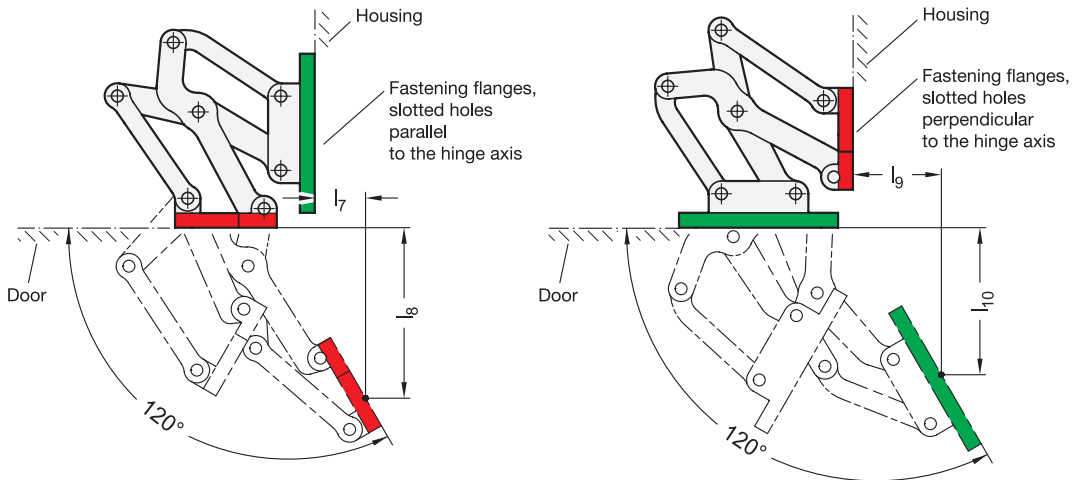

Examples of use

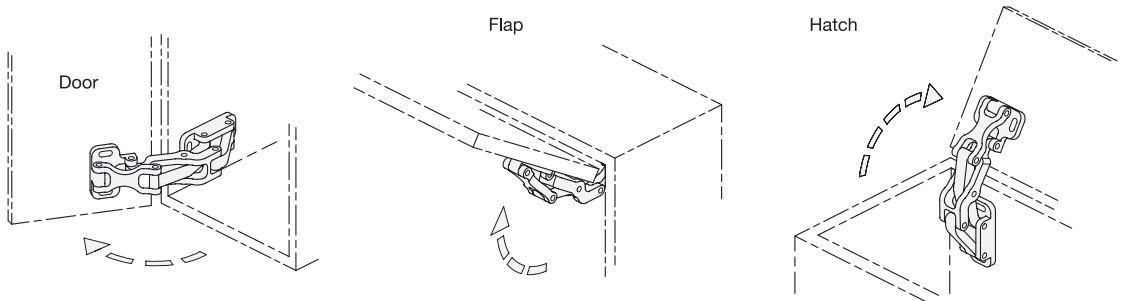

Adjustment and fastening options

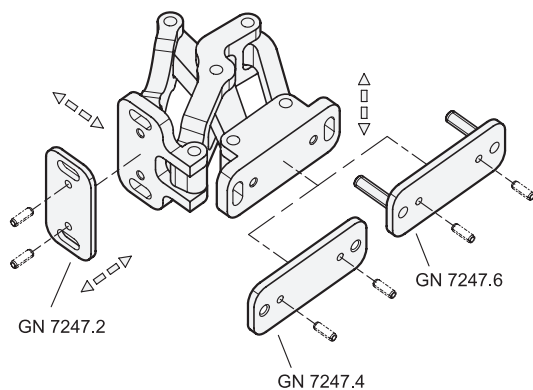

The multiple-joint hinges can be adjusted in three planes during installation. For example, this allows adjustment for tolerances or establishing of required compressive forces for seals. Two planes can be adjusted via parallel or perpendicular slots in the fastening flanges. In the third plane, position corrections can be made using the Stainless Steel-Spacer plates GN 7247.2. Stainless Steel-Plates with tapped holes GN 7247.4 as well as Stainless Steel-Plates with threaded studs GN 7247.6 are also available for fastening the hinges. The latter can be welded on or inserted through the wall from the outside and fastened in place. The holes d_2 receive tensioning or positioning pins, making it easy to position the hinge. This also prevents unintended turning or slipping under load. The pins cannot be removed for subsequent adjustment.

Design variants

Doors, flaps and hatches can be inset, flush or mitered. The maximum wall thicknesses and bend sizes for sheet metal constructions given below arise from the respective installation type.

1. Fastening flange mounted to the housing with slots parallel to the hinge axis:

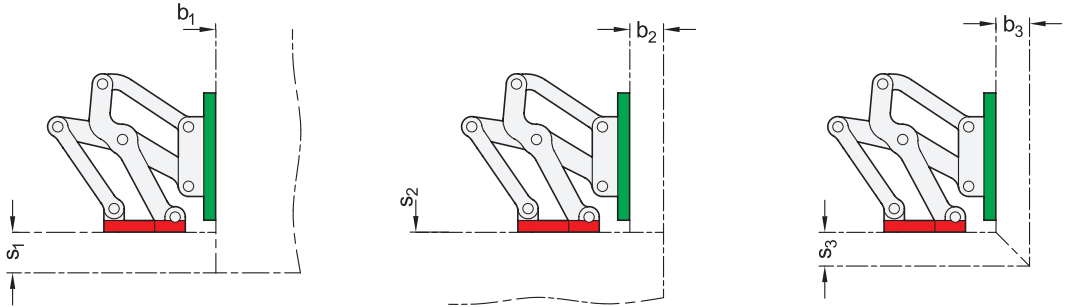

l_1	$s_1 \text{ max.}$	b_1	s_2	$b_2 \text{ max.}$	$s_3 \text{ max.}$	$b_3 \text{ max.}$
75	24	1 ... ∞	1 ... ∞	20	20	20

2. Fastening flange mounted to the housing with slots perpendicular to the hinge axis:

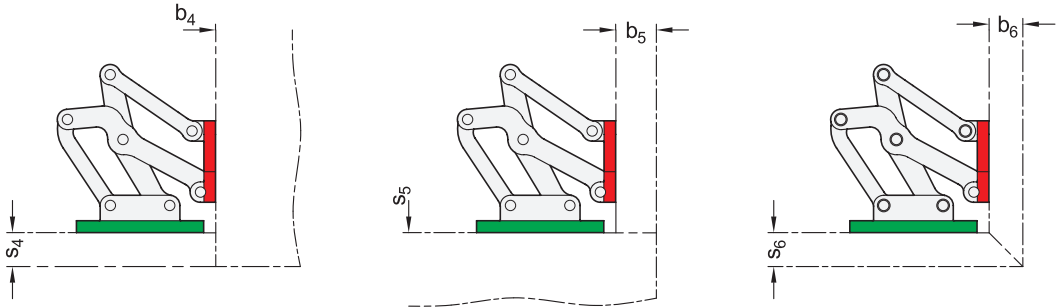

l_1	$s_4 \text{ max.}$	b_4	s_5	$b_5 \text{ max.}$	$s_6 \text{ max.}$	$b_6 \text{ max.}$
75	20	1 ... ∞	1 ... ∞	24	20	20

The design variants shown represent standard installation conditions. If the installation position of the hinge is changed or one of the two wall thickness dimensions is lower than s or b , the maximum achievable dimensions change independently of each other. This makes it possible in some cases to work with larger wall thickness dimensions than those specified with the same hinge size. A simple design check via CAD or a test setup is therefore recommended.



Example of an assembly

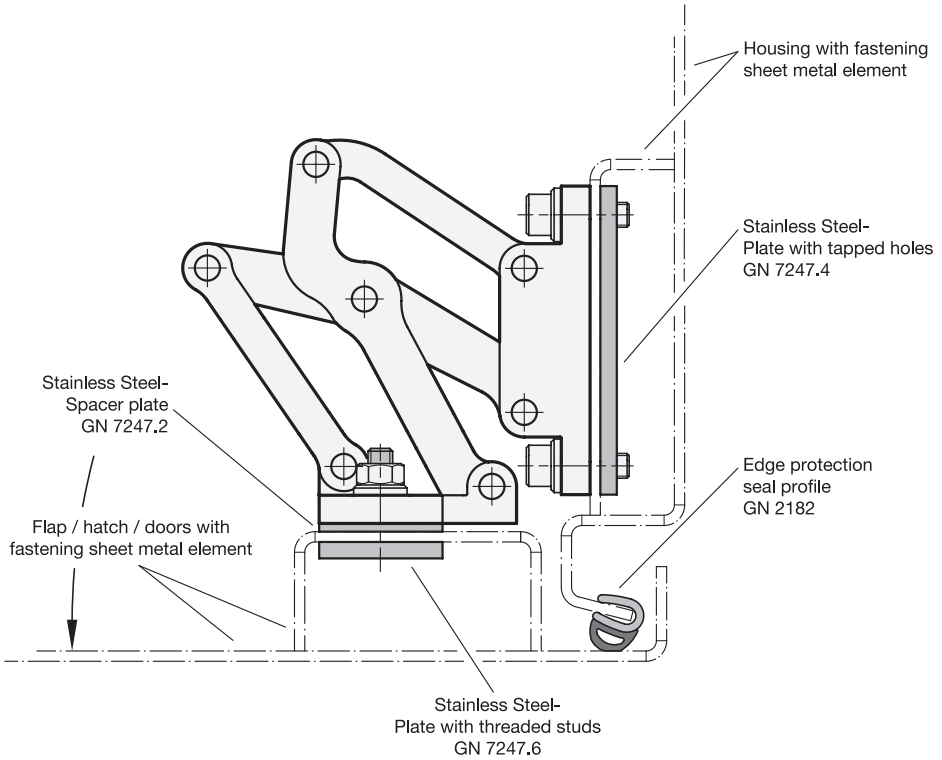

Load capacity

The maximum load of the multiple-joint hinge specified below applies to the standard use cases and serves for orientation in the case of deviating applications. The resulting forces lead to slight elastic deformation, which can be compensated for by means of the adjustment options, if necessary.

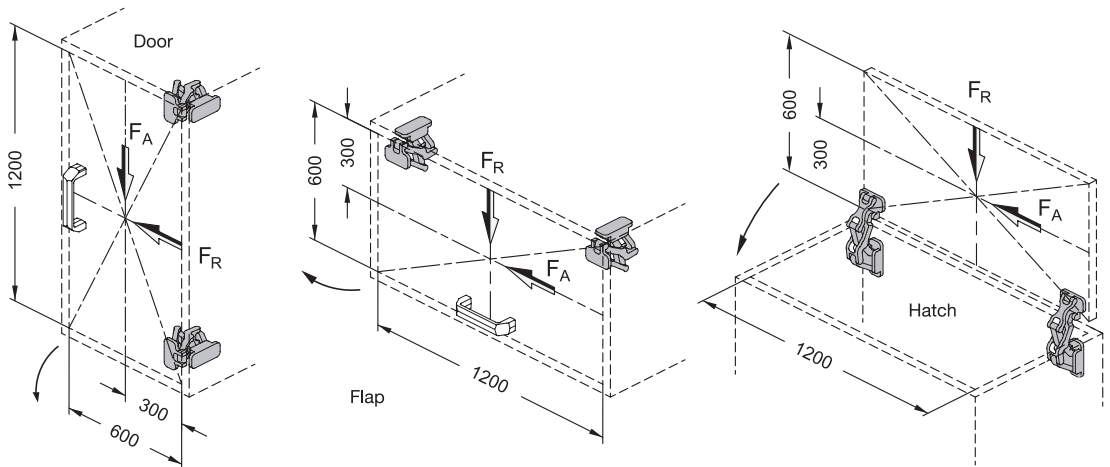

Load capacity per hinge pair in N		
I_1	F_A (axial)	F_R (radial)
75	650	750

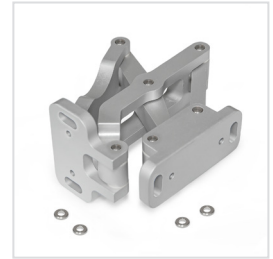
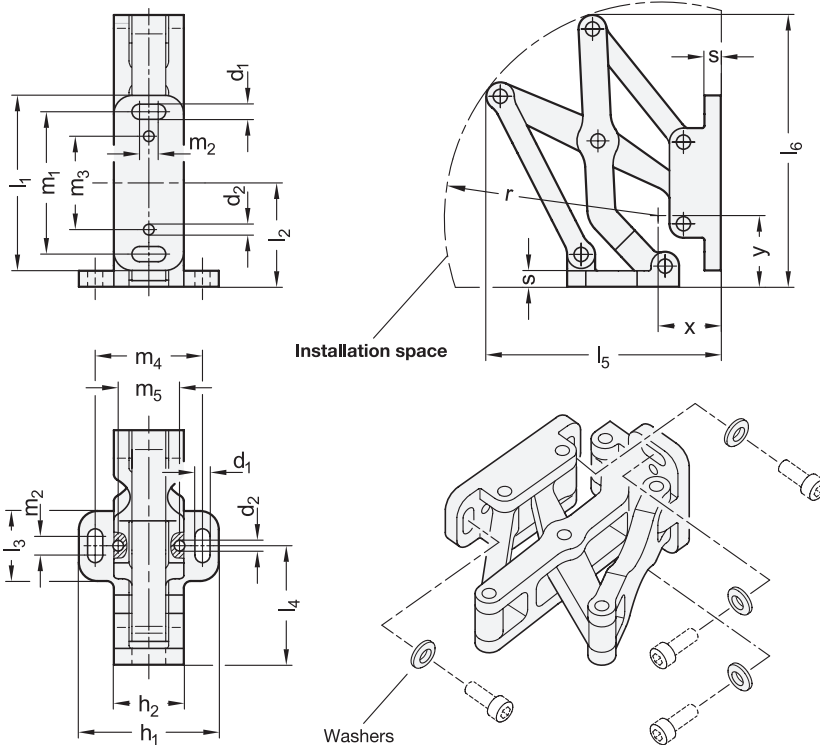

2

l_1	d_1	d_2	h_1	h_2	l_2	l_3	l_4	l_5	l_6	l_7	l_8	l_9	l_{10}	m_1	m_2	m_3	m_4	m_5	r	s	x	y
75	6,5	4	60	30	44,5	30	51	100,5	116,5	74,3	29,5	74	27	61	8	40	46	28	93	7	26	29

Specification

1

3

- Aluminum **AL**
anodized, natural color **EL**
- Hinge pins / washers
Stainless Steel 304
- Friction bearing
Plastic
- self lubricated
- temperature resistant -40 °C to 90 °C
- Stainless Steel characteristics
→ Main Catalogue Page 1489
- RoHS

On request

- other finishes / colors
- other fastening flanges
- other opening angles
- other max. wall thicknesses
- other lifting motion

Information

The multiple-joint hinge GN 7247 is installed on the inside of doors, flaps and hatches to save space and ensure protection against vandalism. The hinge has a maximum opening angle of 180°, which provides optimal accessibility and avoids the blocking of escape routes by open doors, for example.

Use of this hinge type leaves housing exteriors free of attachments that do not match the design or that should be avoided entirely in the interests of fast and easy cleaning.

Multiple-joint hinges are generally used in pairs. For higher loads, e.g. from large doors, these can be supplemented with additional hinges. Four reinforced washers are supplied, which can be used with fastening screws of thread size M6.

see also...

- Stainless Steel-Spacer plates GN 7247.2 → Page 38
- Stainless Steel-Plates GN 7247.4 (with tapped holes) → Page 39
- Stainless Steel-Plates GN 7247.6 (with threaded studs) → Page 40

How to order

GN 7247-AL-75-EL

1	Material
2	l_1
3	Finish / Color

Installation position - pivot characteristics

The multiple-joint hinges can be installed to the housing with the slots on the fastening flanges either parallel or perpendicular to the hinge axis. This results in the two pivot characteristics depicted.

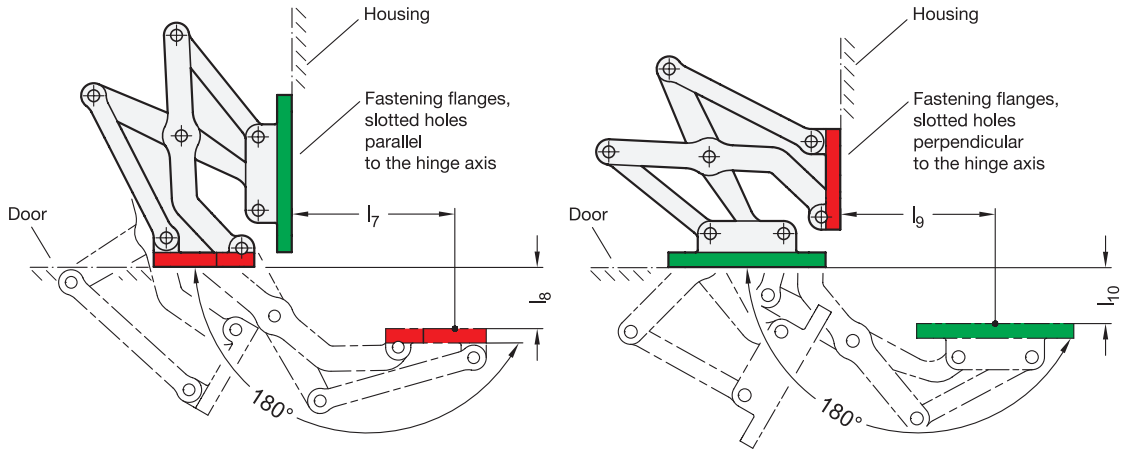

Examples of use

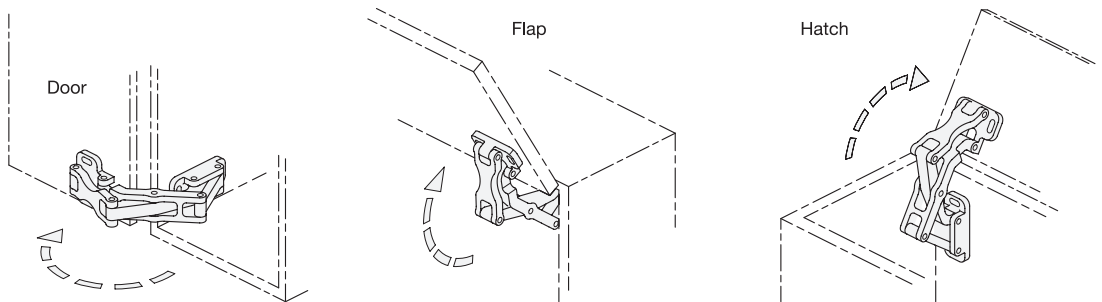

Adjustment and fastening options

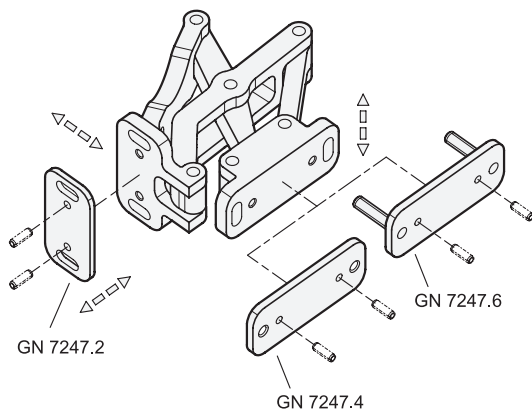

The multiple-joint hinges can be adjusted in three planes during installation. For example, this allows adjustment for tolerances or establishing of required compressive forces for seals. Two planes can be adjusted via parallel or perpendicular slots in the fastening flanges. In the third plane, position corrections can be made using the Stainless Steel-Spacer plates GN 7247.2. Stainless Steel-Plates with tapped holes GN 7247.4 as well as Stainless Steel-Plates with threaded studs GN 7247.6 are also available for fastening the hinges. The latter can be welded on or inserted through the wall from the outside and fastened in place. The holes d_2 receive tensioning or positioning pins, making it easy to position the hinge. This also prevents unintended turning or slipping under load. The pins cannot be removed for subsequent adjustment.

Design variants

Doors, flaps and hatches can be inset, flush or mitered. The maximum wall thicknesses and bend sizes for sheet metal constructions given below arise from the respective installation type.

1. Fastening flange mounted to the housing with slots parallel to the hinge axis:

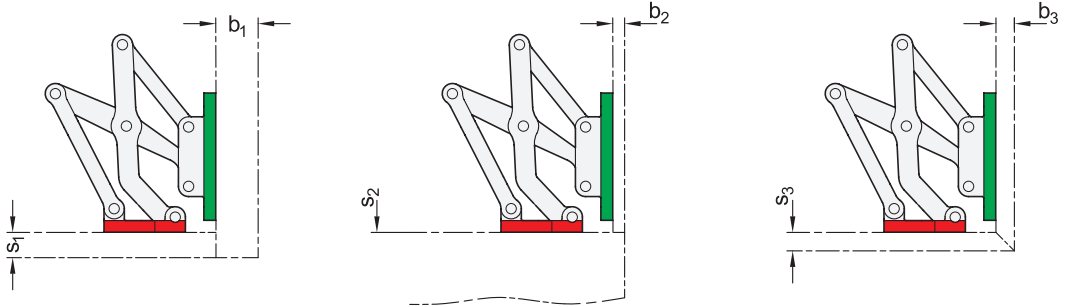

l_1	s_1 max.	b_1	s_2	b_2 max.	s_3 max.	b_3 max.
75	15	24	1 ... ∞	8	11	11

2. Fastening flange mounted to the housing with slots perpendicular to the hinge axis:

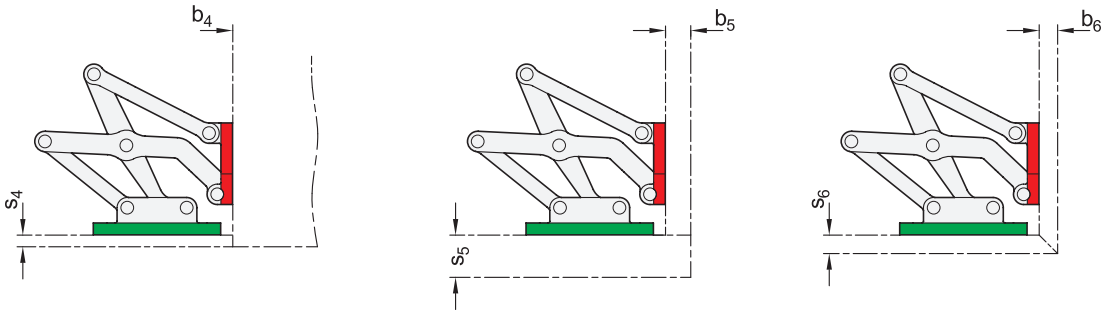

l_1	s_4 max.	b_4	s_5	b_5 max.	s_6 max.	b_6 max.
75	8	1 ... ∞	24	15	11	11

The design variants shown represent standard installation conditions. If the installation position of the hinge is changed or one of the two wall thickness dimensions is lower than s or b , the maximum achievable dimensions change independently of each other. This makes it possible in some cases to work with larger wall thickness dimensions than those specified with the same hinge size. A simple design check via CAD or a test setup is therefore recommended.



Example of an assembly

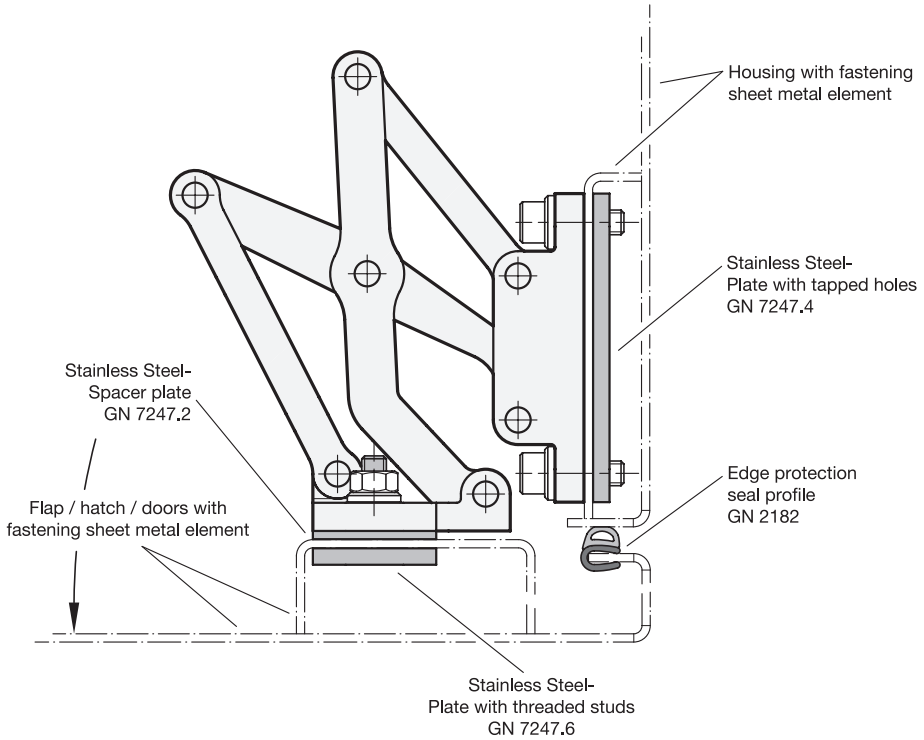

Load capacity

The maximum load of the multiple-joint hinge specified below applies to the standard use cases and serves for orientation in the case of deviating applications. The resulting forces lead to slight elastic deformation, which can be compensated for by means of the adjustment options, if necessary.

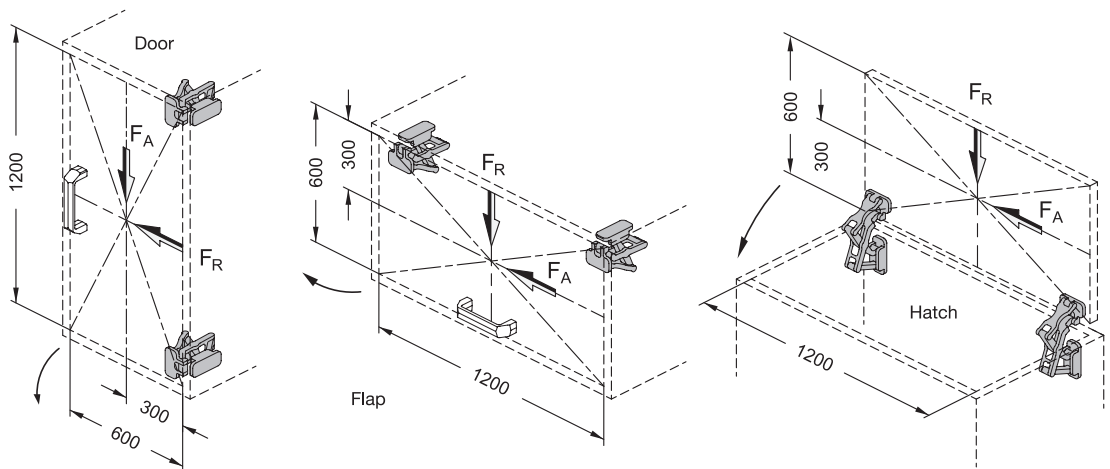

Load capacity per hinge pair in N

I_1	F_A (axial)	F_R (radial)
75	650	750

GN 7247.2 Stainless Steel-Spacer plates

for hinges GN 7241, GN 7243, GN 7247

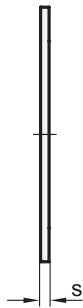
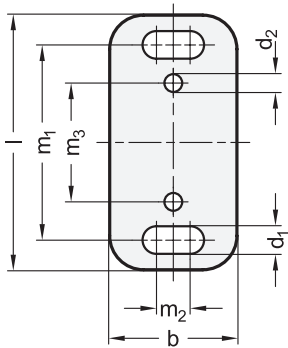

Mounting example

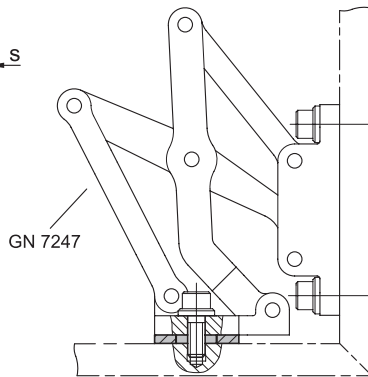

ROSTFREI
Inox
Stainless
Steel

2 3

Length l	s	1	2	b	d ₁	d ₂	m ₁	m ₂	m ₃
60	0,5	1	2	30	6,5	4,2	46	8	28

Specification

- Stainless Steel AISI 304 matte, ground **NI** **MT**
- Stainless Steel characteristics → Main Catalogue Page 1489
- RoHS

On request

- other plate thicknesses

Information

Tolerances of chamfers, different sheet metal thicknesses or the use of seals could mean that the mounting surfaces of multiple-joint hinges on the frame and door do not have the desired separating distance.

Stainless Steel-Spacer plates GN 7247.2 are designed with appropriate dimensions as accessories for multiple-joint hinges GN 7241, GN 7243 and GN 7247. They allow for adjustment in the third plane during mounting. Shimmed individually or in combination, they provide the desired position or height compensation on the fastening surfaces.

The holes d₂ receive tensioning or positioning pins, if necessary, making it easy to position the spacer plates and the multiple-joint hinges.

siehe auch...

- Stainless Steel-Plates GN 7247.6 (with threaded studs) → Page 40

How to order

1 2 3 4
GN 7247.2-NI-60-1-MT

- | | |
|---|----------|
| 1 | Material |
| 2 | Length l |
| 3 | s |
| 4 | Finish |

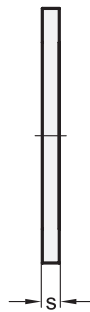
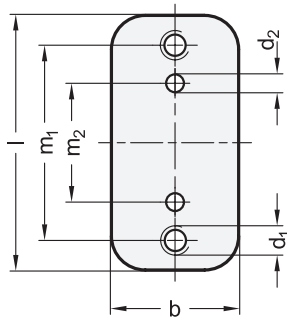

Mounting example

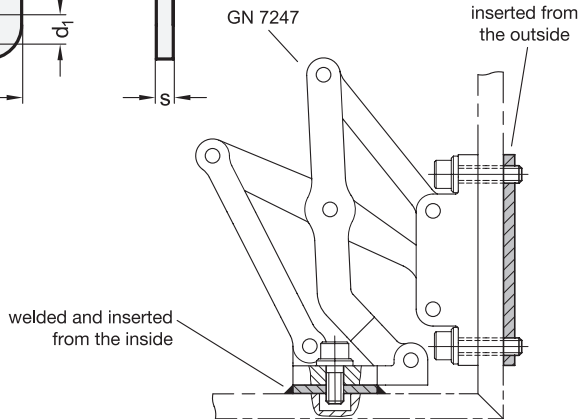

ROSTFREI®
Inox
Stainless
Steel

2

Length l	b	d ₁	d ₂	m ₁	m ₂	s
60	30	M 6	4	46	28	4
75	30	M 6	4	61	40	4

Specification

1

3

- Stainless Steel AISI 304 matte, ground **NI** **MT**
- Stainless Steel characteristics
→ Main Catalogue Page 1489

• RoHS

On request

- other plate sizes
- other plate geometries

Information

Stainless Steel-Plates with tapped holes GN 7247.4 are designed with appropriate dimensions to be used as accessories for the fastening flanges of multiple-joint hinges GN 7241, GN 7243 and GN 7247.

The Stainless Steel-Plates are fastened from the outside via through-holes in the housing wall or alternatively by welding to the inside of the wall. This results in effective protection against vandalism, and the outside of the housing remain free of attachments that do not match the design or that should be avoided entirely in the interests of easy cleaning.

They make threaded holes, nuts and washers unnecessary during installation. This eliminates the labor-intensive pre-installation of such parts as well as the need to hold them in place during tightening or loosening. The plate thickness *s* corresponds to the minimum screw-in depth of thread *d*₁, which should be fully achieved.

The holes *d*₂ receive tensioning or positioning pins, if necessary, making it easy to position the plates and the multiple-joint hinges.

see also...

- Stainless Steel-Plates GN 7247.6 (with threaded studs) → Page 40

How to order

GN 7247.4-NI-75-MT

1	Material
2	Length l
3	Finish

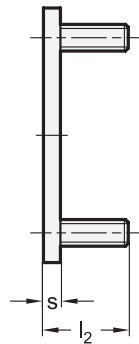
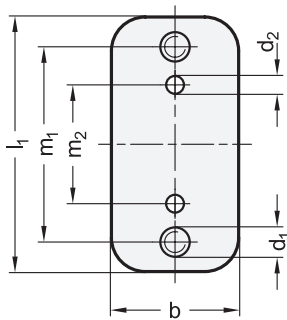

Mounting example

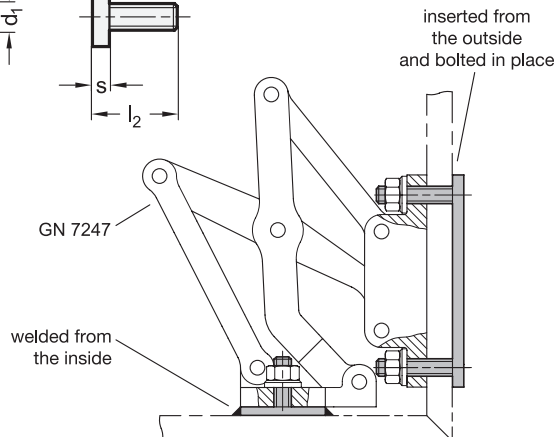

ROSTFREI®
Inox
Stainless
Steel

² l ₁	³ l ₂			b	d ₁	d ₂	m ₁	m ₂	s
60	20	25	30	30	M 6	4	46	28	4
75	20	25	30	30	M 6	4	61	40	4

Specification

- Stainless Steel AISI 304 matte, ground NI MT
- Threaded studs Stainless Steel AISI 304 pressed-in
- Stainless Steel characteristics → Main Catalogue Page 1489
- RoHS

On request

- other threaded stud lengths
- other plate sizes
- other plate geometries

Information

Stainless Steel-Plates GN 7247.6 are designed with appropriate dimensions to be used as accessories for the fastening flanges of hinges GN 7241, GN 7243 and GN 7247.

The Stainless Steel-Plates are fastened from the outside via through-holes in the housing wall or alternatively by welding to the inside of the wall. This results in effective protection against vandalism, and the outside of the housing remain free of attachments that do not match the design or that should be avoided entirely in the interests of easy cleaning.

They make threaded holes, bolts and washers unnecessary during installation. This eliminates the labor-intensive pre-installation of such parts as well as the need to hold them in place during tightening or loosening.

The holes d₂ receive tensioning or positioning pins, if necessary, making it easy to position the plates and the multiple-joint hinges.

see also...

- Stainless Steel-Plates GN 7247.4 (with tapped holes) → Page 39
- Stainless Steel-Spacer plates GN 7247.2 → Page 38

How to order	1 Material
	2 l ₁
GN 7247.6-NI-60-30-MT	3 l ₂
	4 Finish

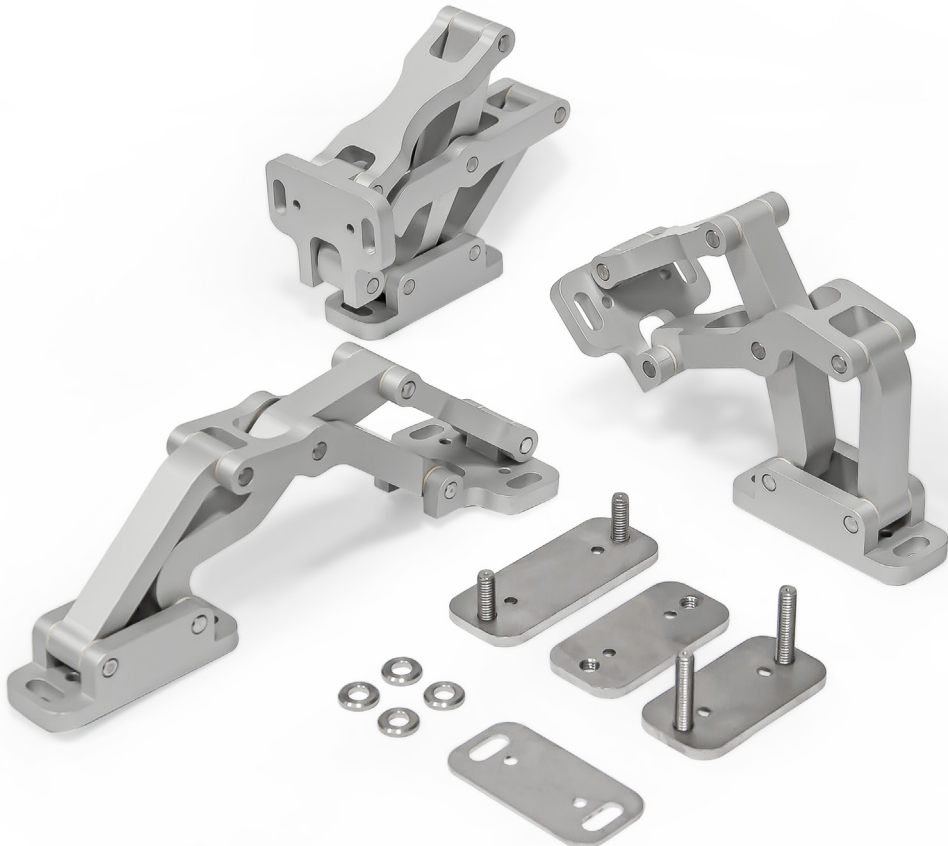

Aluminum-Multiple-joint hinges with accessories

Design

The following principles should be observed in mounting the hinge connection and mounting the multiple-joint hinges. This will help prevent wedging or clamping and ensure even, low-wear movement. The multiple-joint hinge will remain in operation for a long time as a result.

- Multiple-joint hinges are installed at least in pairs.
- Multiple-joint hinges are aligned parallel to each other.
- Multiple-joint hinges are aligned in a plane parallel to the door, flap or hatch opening.
- Suitable limiting and stop elements are used to prevent the hinge mechanism from opening past the intended opening angle (less than 0° or more than 90°, 120° or 180°).
- All hinges participating in the movement bear roughly the same load (lever, center of gravity, ...).
- The indicated load capacity of the multiple-joint hinges is not exceeded.

Mounting

In addition to the precautions to be taken during mounting, a number of additional points must be noted.

- The fixing screws must have at least strength class 8.8 or A2-70 and must be tightened with the specified torque. Reinforced washers are included with the aluminum hinges. Washers, e.g. as per DIN 125 A or ISO 7089, are used with the stainless steel hinges.
- The multiple-joint hinges may not be installed or aligned using force, such as with a hammer or pry bar.
- If a hinge is stuck or warped, or starts making noise when moved, the cause must be determined and rectified by aligning and adjusting the hinge.

Adjustment

The slotted holes of the fixing angle pieces or fastening flanges can be used to adjust the hinges in two planes. For the third plane, the spacer plates GN 2370 are available as compensation and shimming accessories for the Stainless Steel Multiple-joint hinges, and the spacer plates GN 7247.2 are available for aluminum multiple-joint hinges.

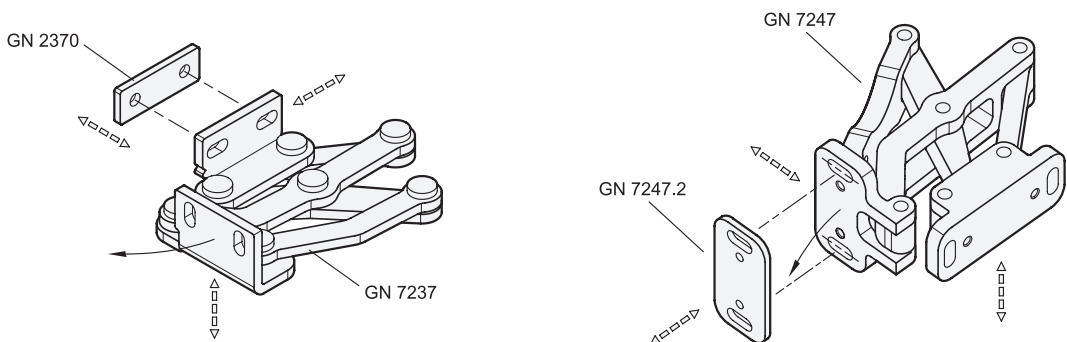

Modification

Subsequent modification of the hinges by polishing, coating, welding or connecting additional components such as pneumatic springs, latching elements, etc. can impair the functionality of the hinge or lead to a defect. Changes should be tested in a test setup first to ensure reliable functioning.

Safety

When opening and closing the multiple-joint hinges, there is a risk of injury from the hinge mechanism. Fingers can be caught or crushed.

Load capacity

The maximum load capacity of the multiple-joint hinges depends on the hinge cross-section, the materials of the individual parts and plain bearing bush as well as the installation situation (flap, hatch or door). For example, the larger cross-section of aluminum multiple-joint hinges makes them better suited for installation in doors than the stainless steel versions, which offer advantages in other areas. Distribution of the load also plays an important role. In the optimal case, the load should be evenly distributed among all hinges.

The load capacity values given for the multiple-joint hinges are based on the following sources of information:

- Values from the simulation software
- Calculation based on material data
- Tensile and compression tests
- Endurance tests and empirical values

The endurance testing of the hinges in door installations was carried out under the following conditions:

- Hinge arrangement as a pair
- Adherence to the mounting information
- Warp-resistant test set-up
- Standard door (flap or hatch) with overall dimensions 1200 x 600 mm
- Even distribution of the load F_A over the entire area (center of gravity)
- At least 15,000 test cycles (Opening and closing once = one cycle)
- Staged increasing of the load

The wear, the movement characteristics and the elastic deformation were evaluated after every phase of the endurance test.

If more than two hinges are installed, the permissible loads are correspondingly higher. The load capacity increases linearly as long as the load is evenly distributed between the hinges. If this is not the case, a corresponding safety factor must be taken into account. Alternatively, it is recommended that the function be tested in a test setup.

Deformation

If the maximum load is applied to the hinges, slight elastic deformation will occur, but this will have no effect on the functioning. In the least favorable load scenario (door installation) a deformation or lowering of $\approx 1\text{-}1.5$ mm is permissible. The hinges can be adjusted, if necessary, using the available adjustment options.

Lubrication and maintenance

The joints of the multiple-joint hinges have high-quality plain bearing bushes with lifetime lubrication. Under normal conditions, no further lubrication of the bearings is required.

Operational temperatures

Depending on the hinge type (Stainless Steel or aluminum), various plain bearing materials are installed, which determine the maximum temperature range. The following ranges are permissible:

- Stainless Steel-Multiple-joint hinges: Bronze bushings, temperature range -200 °C to 280 °C
- Aluminum multiple-joint hinges: Plastic bushings, temperature range -40 °C to 90 °C (briefly to 150 °C)

Standard door for endurance test

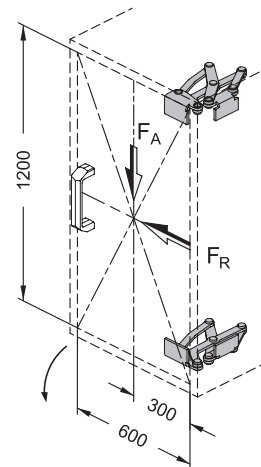

Accessories

In addition to the spacer plates available for compensating or positioning in the third plane, there are two other accessory parts that enable simple and universal fastening of the multiple-joint hinges.

- Stainless Steel-Plates with threaded studs (GN 2376 and GN 7247.6).
- Stainless Steel-Plates with tapped holes (GN 2372 and GN 7247.4).

Using the different plates can eliminate the need for other parts during mounting. For example, bolts, nuts or even washers as well as any threaded holes in the surrounding construction can be eliminated in this way.

If necessary, the plates also be welded to the housing, allowing the hinges

to be removed and reinstalled as often as necessary for maintenance or repairs. If the plates are installed inside the housing, the exterior surfaces remain free of visible parts. This is ideal for applications with special design standards or when simple cleaning is required. Installed on the inside or outside, the plates also protect against vandalism because there are no accessible fastening screws.

Special versions

In the case of special requirements, it may be that none of the standard hinges will serve as desired, such as when the kinematics leads to collisions or additional options are required. To still offer a solution for such cases, it is possible to develop hinges with changes to the following specifications, given a sufficient minimum order:

- **Other opening angle:** Based on the seven joints, it is fundamentally possible to realize opening angles from 0 to 180°. Depending on the application, an angle of up to 270° is possible. For large opening angles, a simple design check via CAD is recommended in advance. This allows collisions to be identified early and corrected.
- **Other fixing angle piece or fastening flange:** Depending on the needs, different fastening geometries can be provided. The position and quantity of fastening holes can be changed as needed. Only the connection to the hinge itself must remain identical if a standard hinge is to be used.
- **Other max. wall thicknesses:** If the listed nominal wall thicknesses of the housing, doors, flaps and hatches are not sufficient, the hinges can be modified to permit larger or smaller wall thicknesses with the given opening angle. However, this will alter the movement kinematics slightly.
- **Other lifting motions:** The opening and closing kinematics of a hinge can be changed as desired. For example, a hinge could first perform a lifting motion and then a pivoting motion or vice versa. Collisions with the housing or other nearby parts can be avoided in this way.
- **Other materials:** The multiple-joint hinges can be made of other materials, such as galvanized steel, stainless steel or aluminum to meet special requirements such as low weight, high corrosion resistance or higher load capacity.
- **Other surfaces and colors:** Multiple-joint hinges can be delivered with a variety of surface finishes, such as paint or a plastic coating. Various colors can be applied to the aluminum hinges by anodizing. The stainless steel variants can be blasted, brushed or polished, if desired.
- **With latching:** Multiple-joint hinges can be fitted with latching elements, such as indexing plungers or spring plungers, depending on the application. This allows the hinges to be latched at any positions within the opening angle or to be briefly stopped until a specific force is applied. For example, hatches or flaps can be secured in open position until a maintenance or repair measure is finished.
- **With pneumatic spring connection:** Flaps and hatches are often combined with pneumatic springs that make them easier to open or hold them in a defined end position. To reduce the number of attachments, pneumatic springs can be attached to one of the fixing angle pieces of the hinge itself (generally on one side).
- **With reinforced design:** When installed in doors, Stainless Steel-Multiple-joint hinges can only accept relatively low loads due to their small cross-section. Larger loads can be achieved, if necessary, with a reinforced design consisting of a multi-layered arm geometry (e.g. two or three layers).

Otto Ganter GmbH & Co. KG

Triberger Straße 3
78120 Furtwangen
Germany

Tel. +49 7723 6507-0

Mail info@ganternorm.com

www.ganternorm.com