

# INSTALLATION GUIDELINE

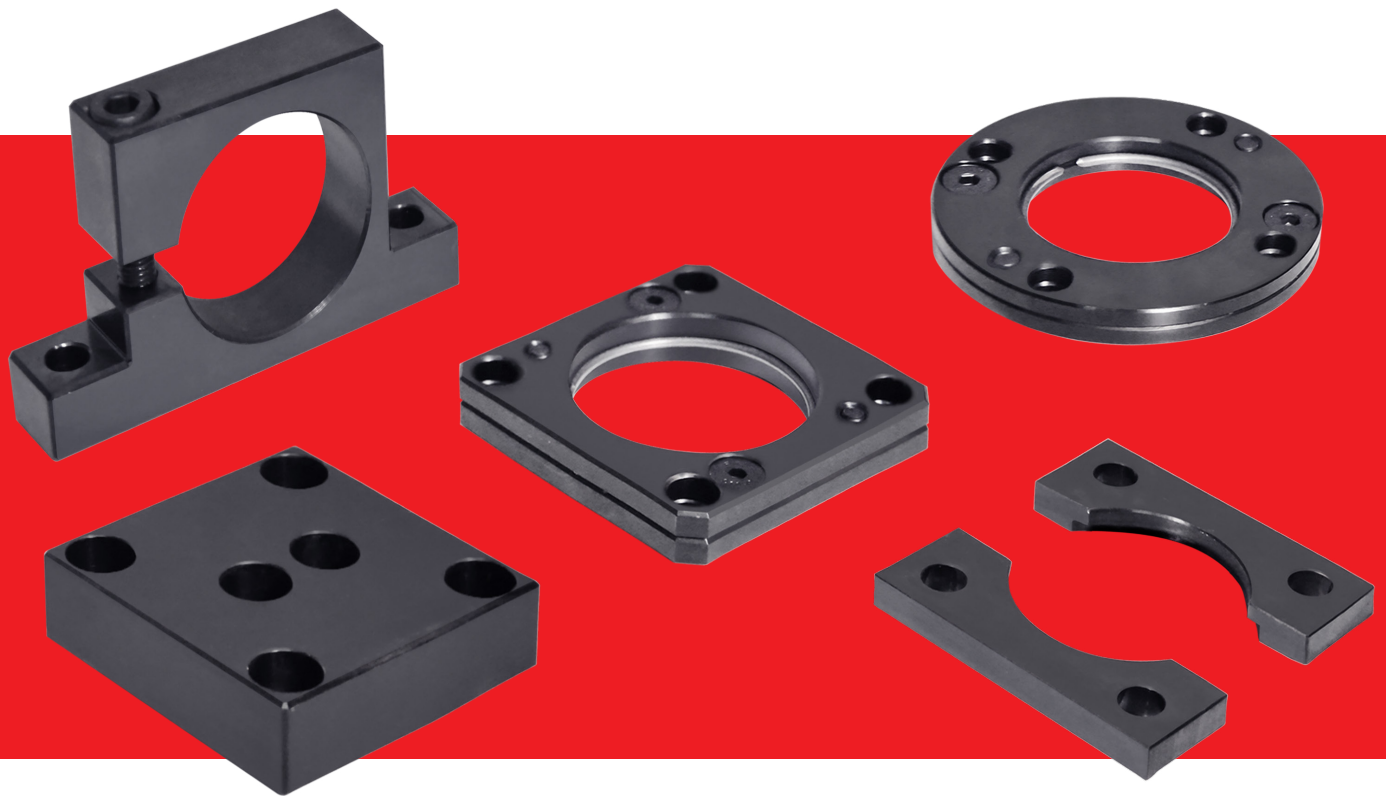

# INSTALLATION GUIDELINE



**EN** A correct fixing of the gas springs prevents damages to products and serious dangers to operators.

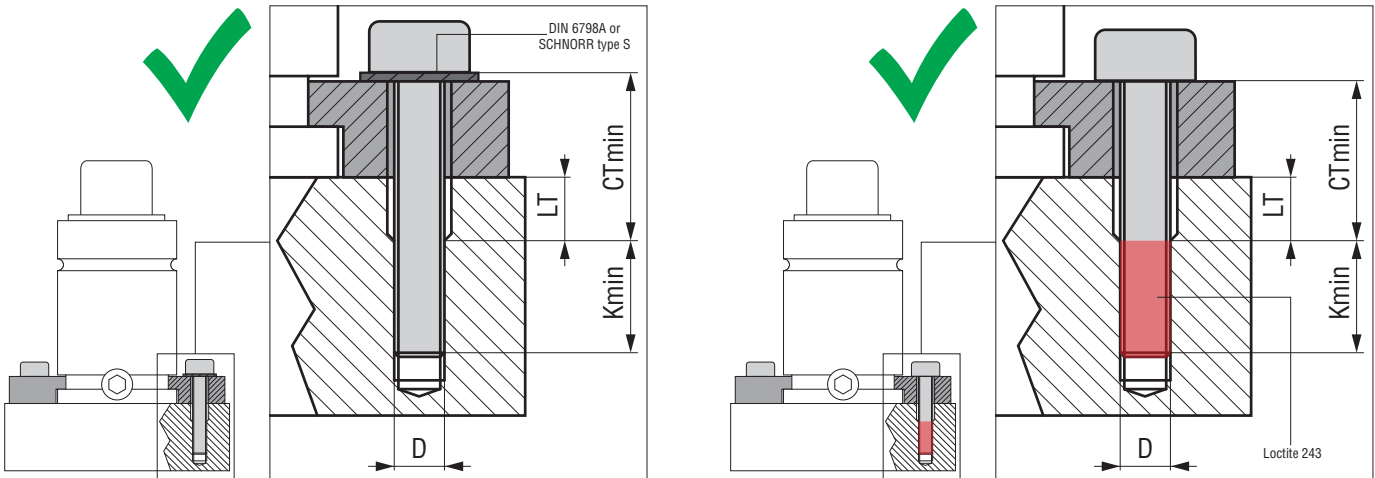

CTmin	Kmin	LT
Free length (min. 2 x D)	Minimum thread engagement (steel = min. 1.5 x D, cast iron = min. 2 x D)	Widening to ensure CTmin

**EN** Always use the suitable threadlocker and/or safety washers on all fixing screws. (They are not represented in the drawings in the following pages).



Safety Washers	
<p>Only for ML, MP, MQ series</p> <p>Conical spring washer provided by Special Springs</p>	<p>DIN 6798A or SCHNORR type S</p>

**EN** It is always possible to use screws belonging to Classes higher than 8.8, such as 9.8, 10.9 and 12.9. Do NOT EXCEED the values of the tightening torque valid for Class 8.8 for any of the screw's Classes you may use (see page 5).

**EN** Gas spring with fixing holes for which value A is bigger than value D (e.g. SC3000 with fixing holes M8x13).

**Installation Example:  $A > D$**

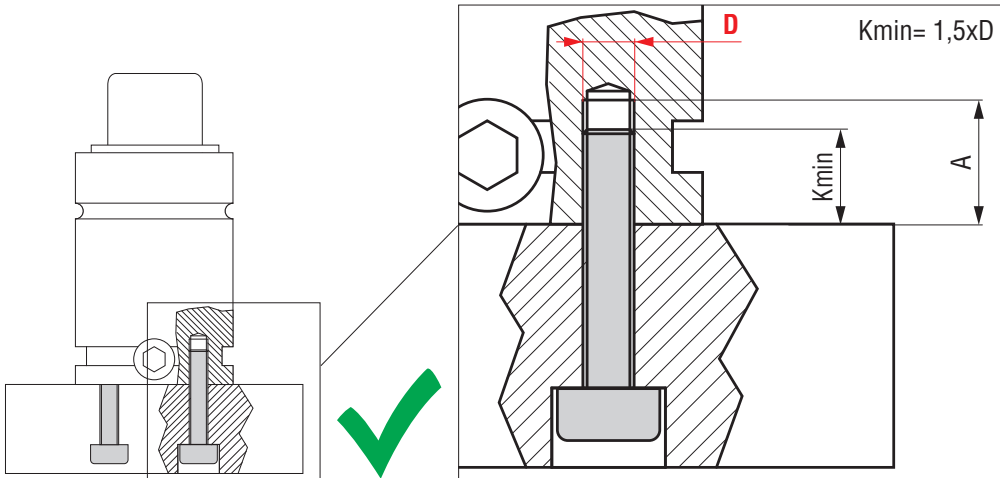

**EN** Gas spring with fixing holes for which value A is smaller than value D (e.g. RV1000 with fixing holes M8x6). In such cases, be careful to use screws with a length long enough to employ the whole usable fixing depth.

**Installation Example:  $A \leq D$**

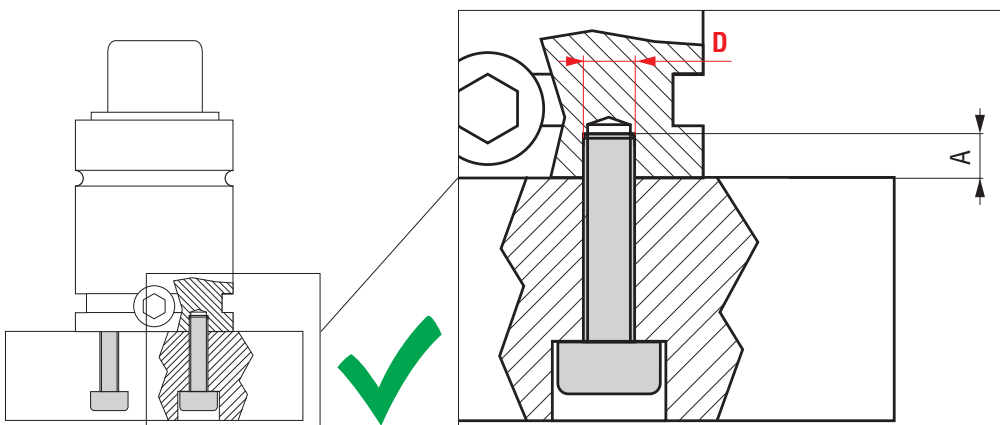

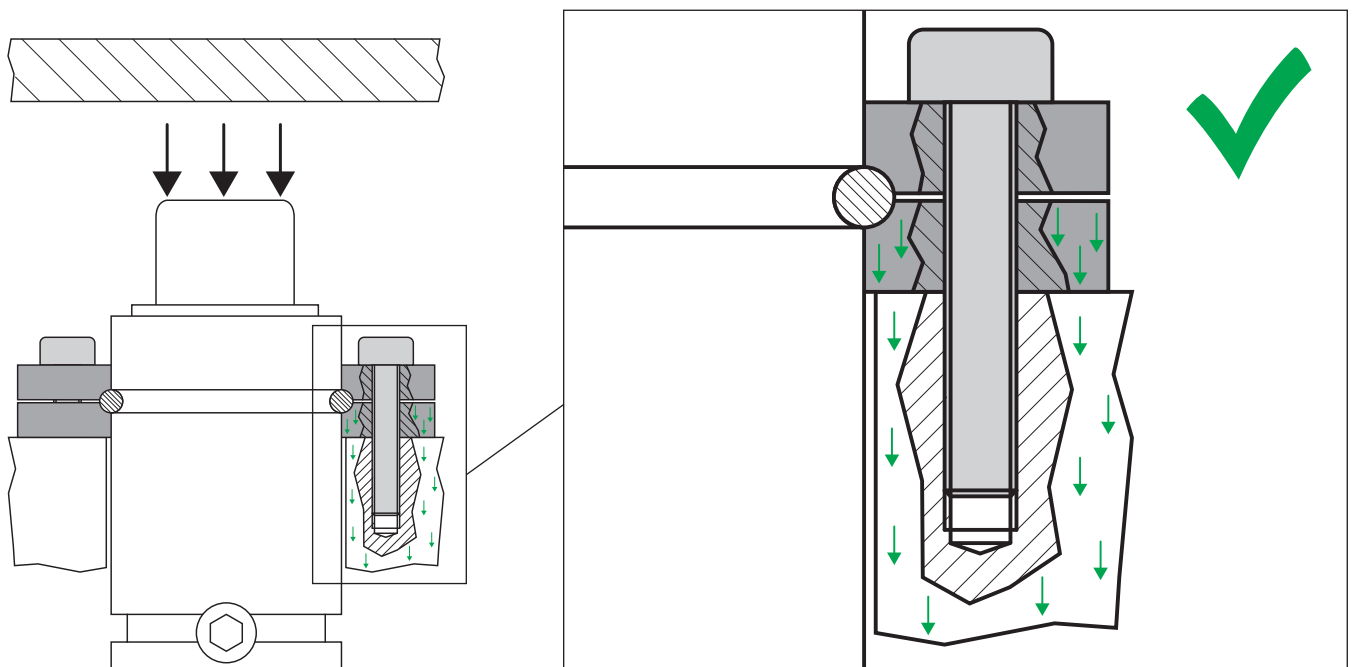
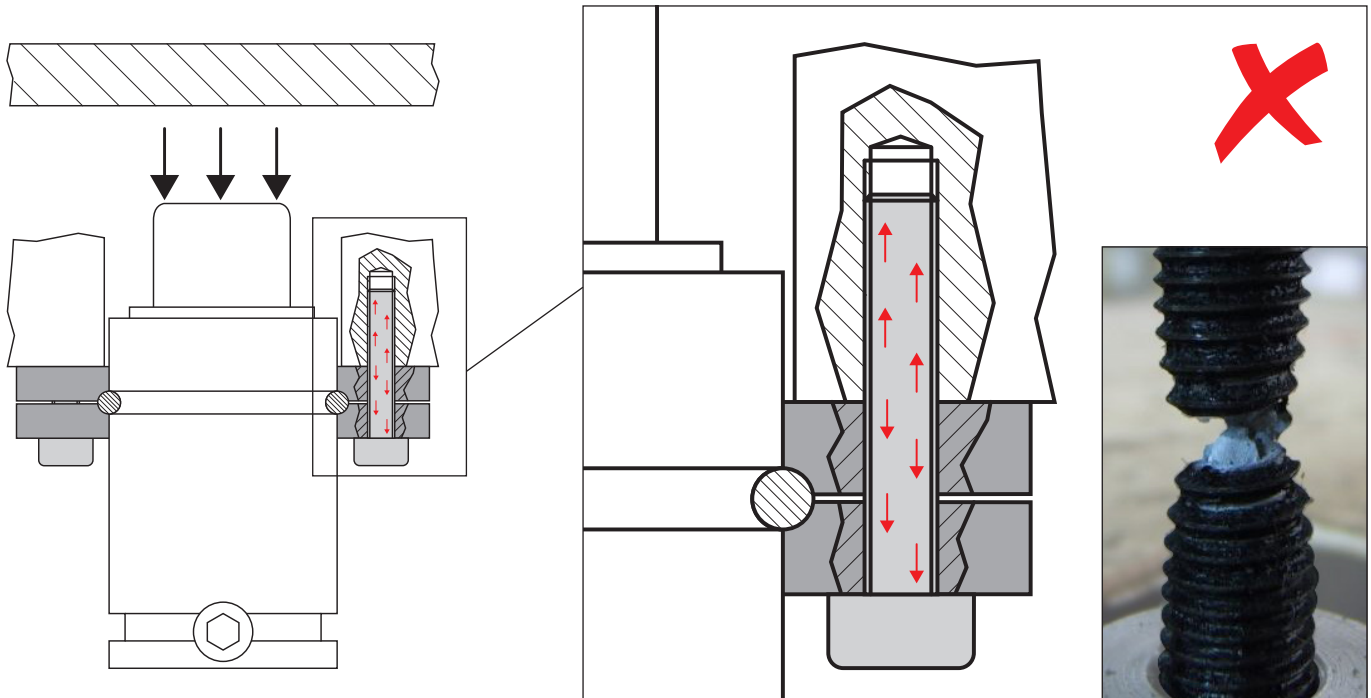

# INSTALLATION GUIDELINE

**EN** Fixing screws shall never be directly strained by the load acting on the gas spring.



**EN** Respect the specified tightening torques and verify always the condition of gas springs and fixings at each intervention on the die.

n.

	<b>UNI EN ISO 21269:2007 class ≥ 8.8</b>	M5	M6	M8	M10	M12	M 16
	<b>Torque force</b>	6 Nm	10 Nm	24 Nm	50 Nm	84 Nm	205 Nm

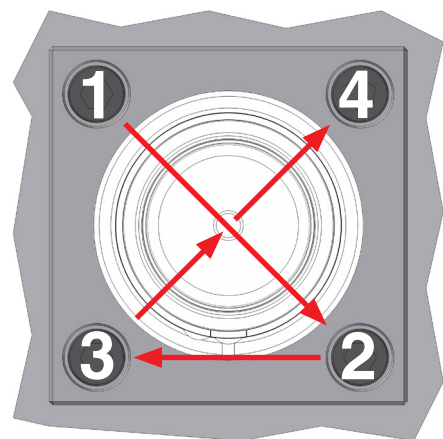
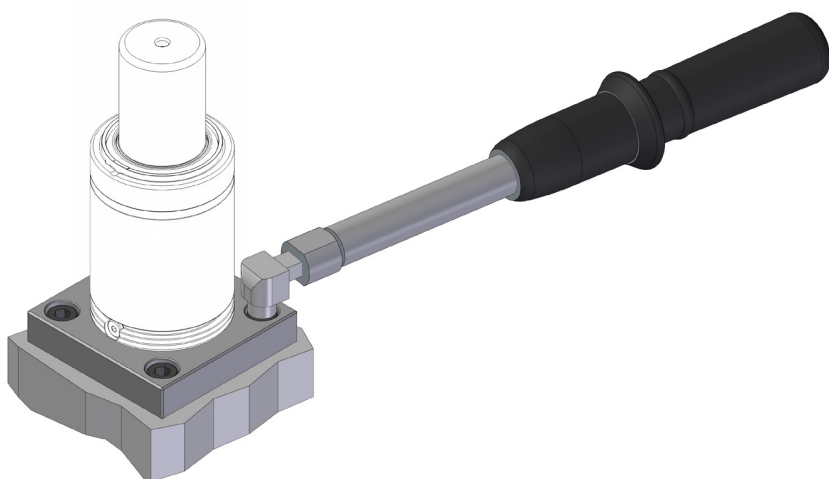

**EN** Tighten all fixing screws by following the order shown in the image (1, 2, 3, 4) and by applying the correct tightening torque. In doing so, the gas springs will be perfectly positioned.

# INSTALLATION GUIDELINE - DROP-IN



Installation examples

## VERTICAL FIXING

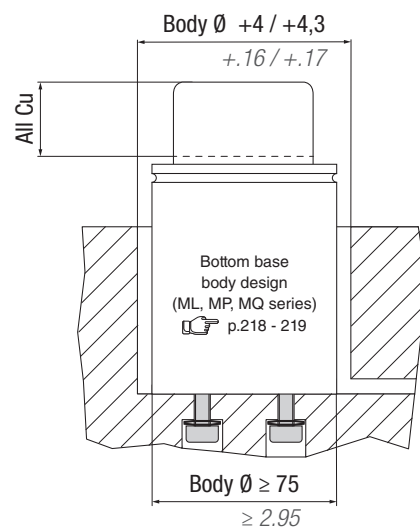
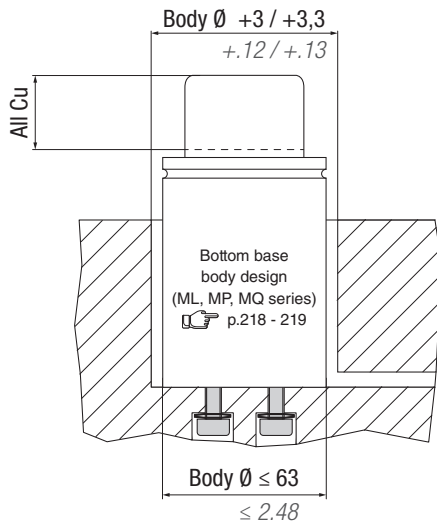
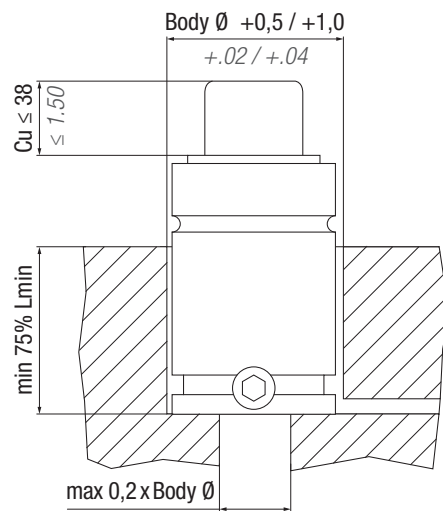
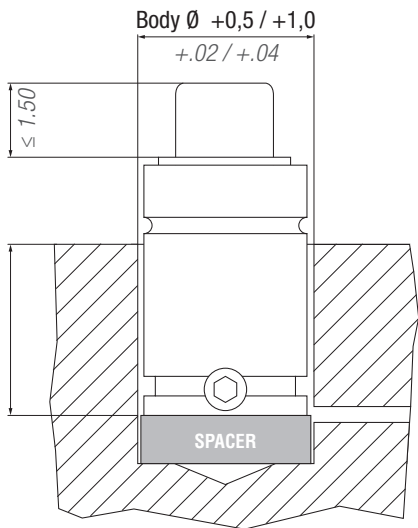
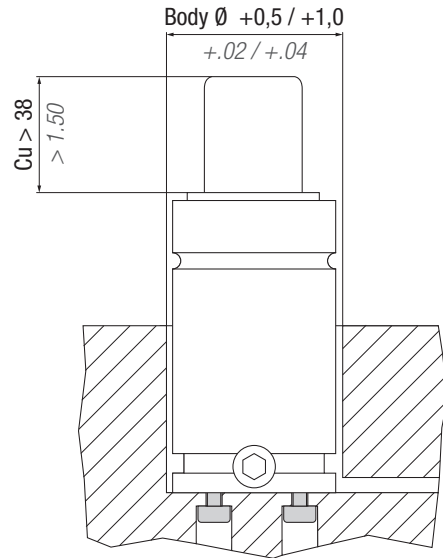
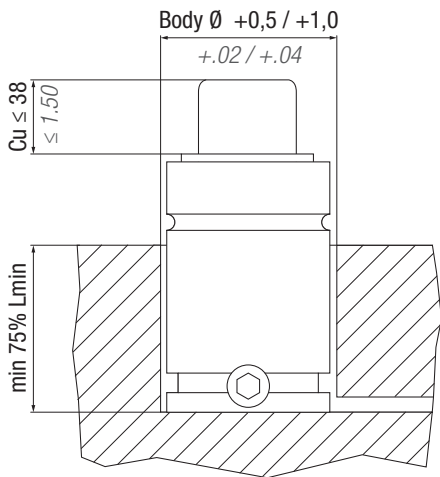

All dimensions in mm / inch

## Installation examples

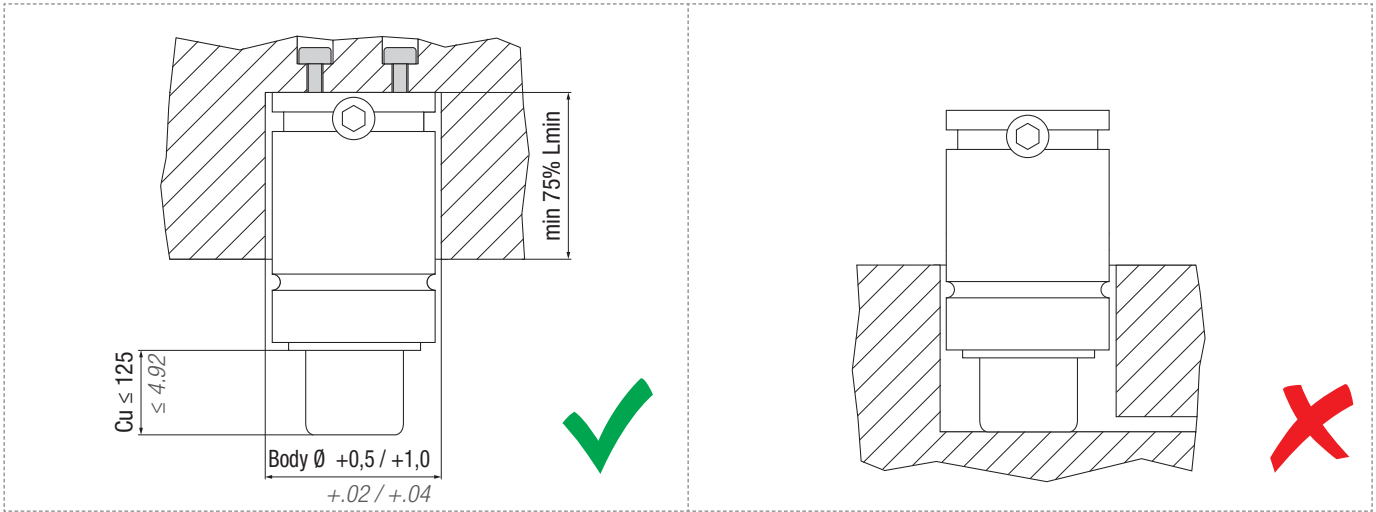

## HORIZONTAL FIXING

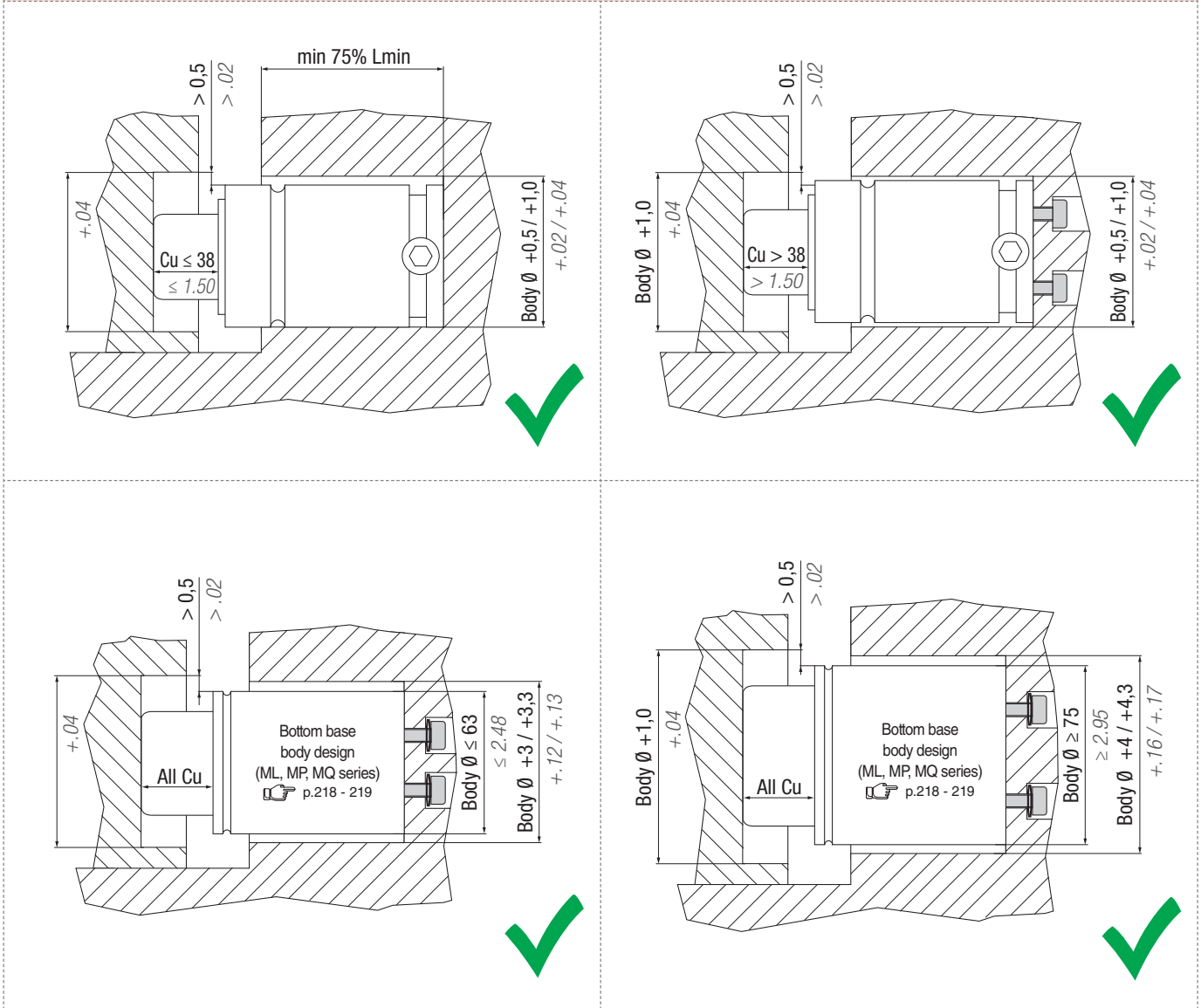

All dimensions in mm / inch

# INSTALLATION GUIDELINE - BOTTOM MOUNT



Installation examples

## FB - FBA - FBB - FBC - FBD - FBF

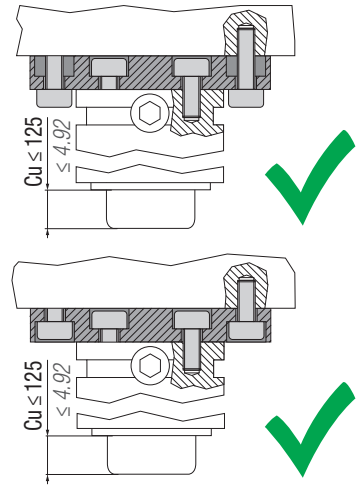
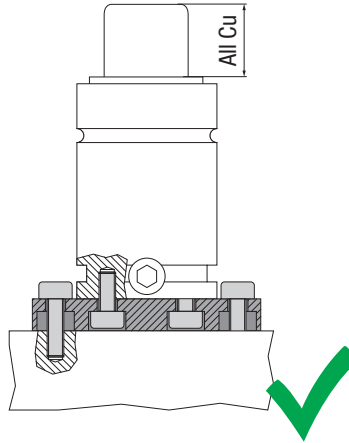
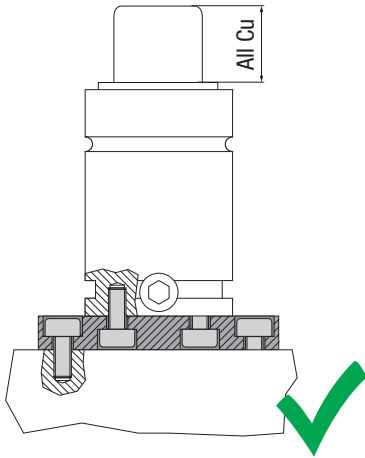

## FBE

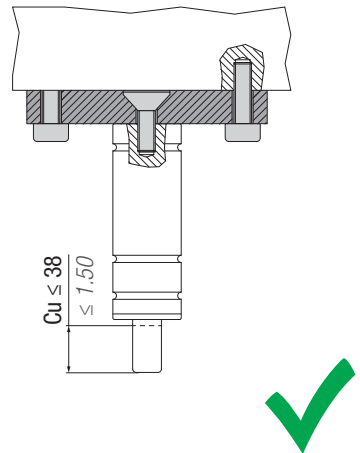
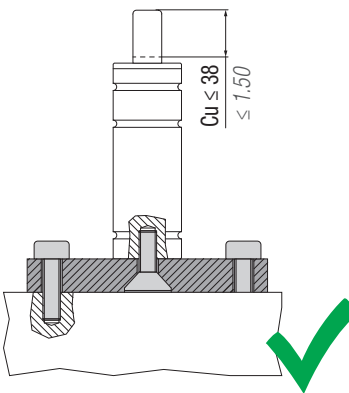
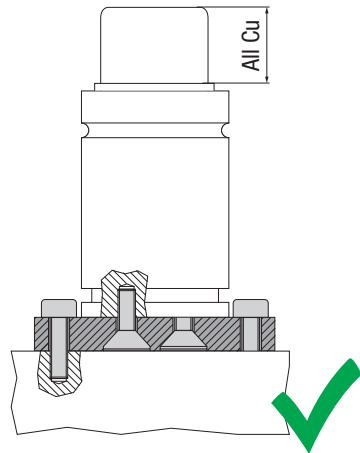
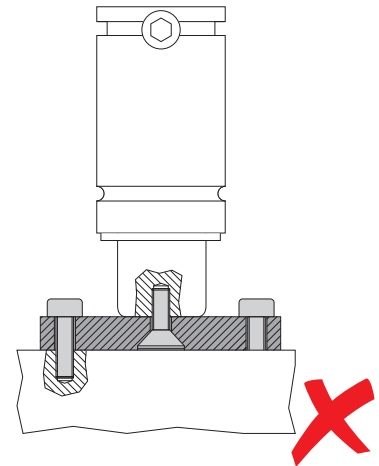
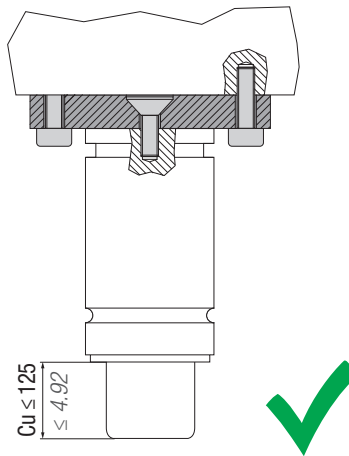
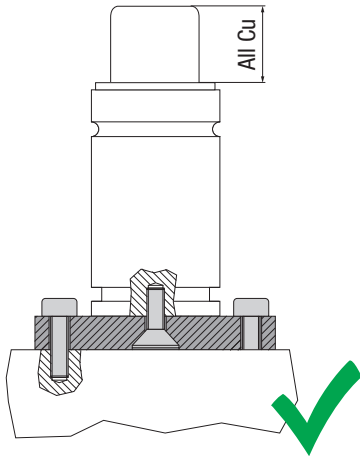

All dimensions in mm / inch

Special Springs



Installation examples

**FCB - FCD - FC - FCC - FCQ - FCQC - FCQB**

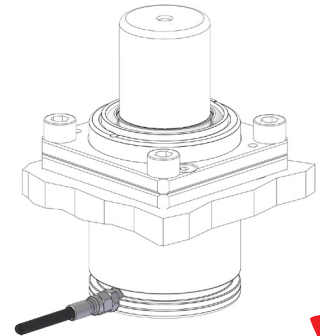
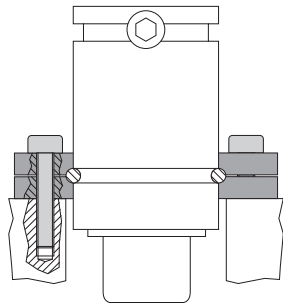
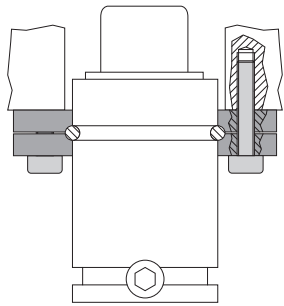
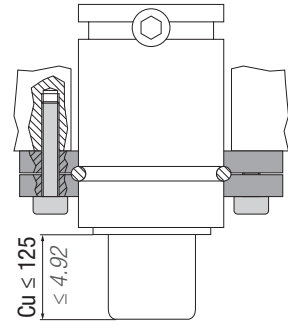
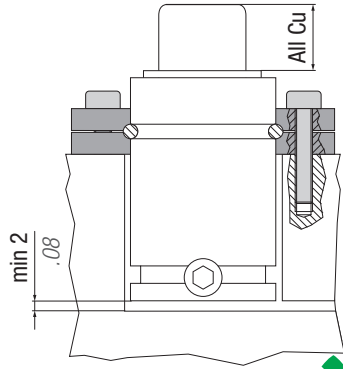
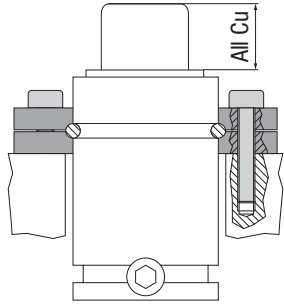

**FC (for body cylinder Ø 12 ÷ 25)**

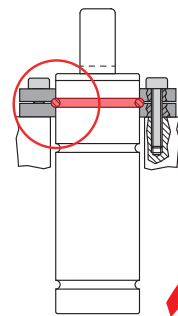
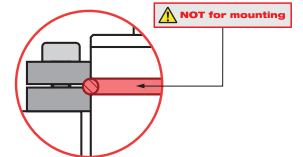
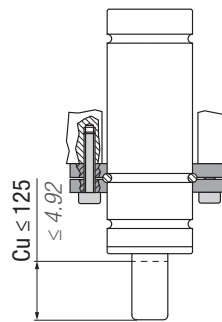
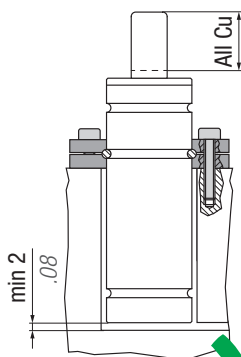
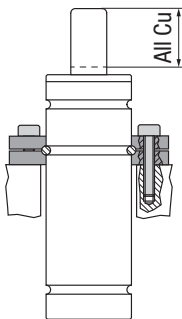

All dimensions in mm /inch

# INSTALLATION GUIDELINE - BRACKET MOUNT



Installation examples

## FS2 - FS2B - FS2A - FS2C

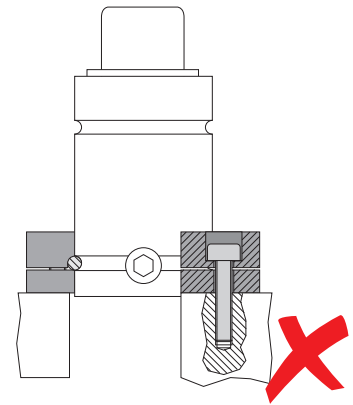
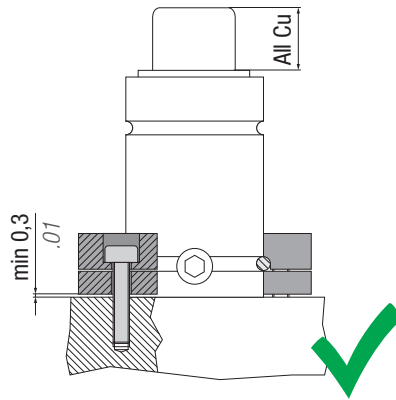
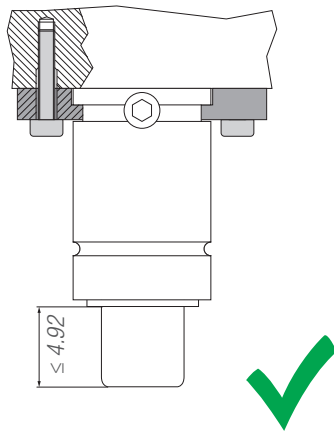
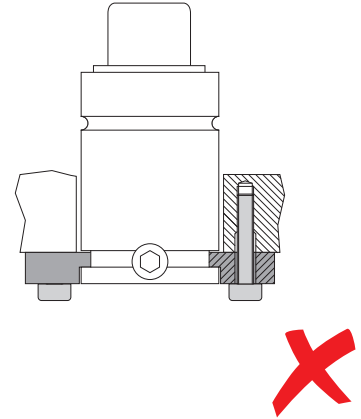
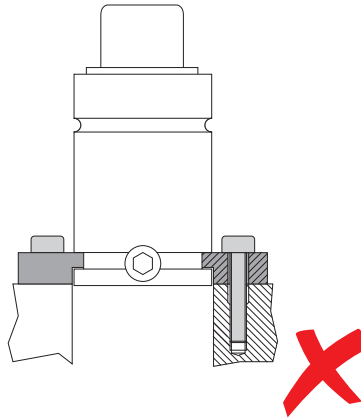
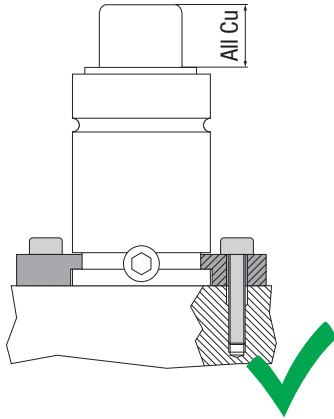

## FS1

## FS3

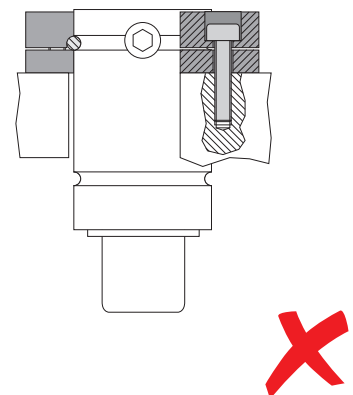
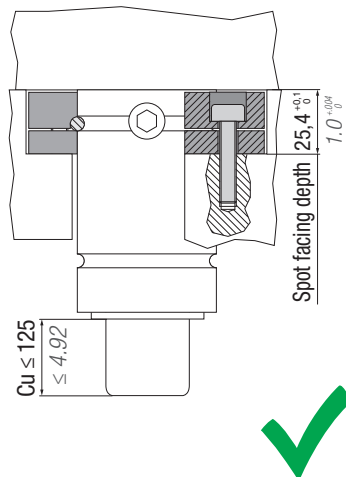
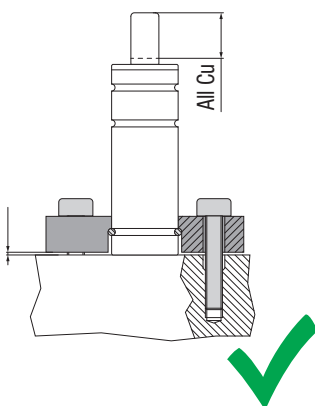

All dimensions in mm / inch

Special Springs

Installation examples

FC (for body cylinder Ø 12 ÷ 25)

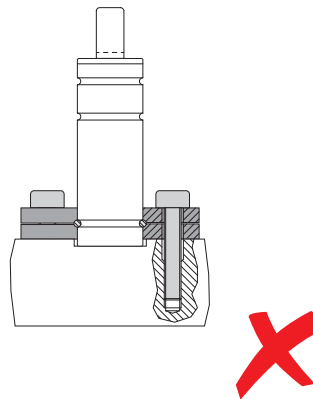
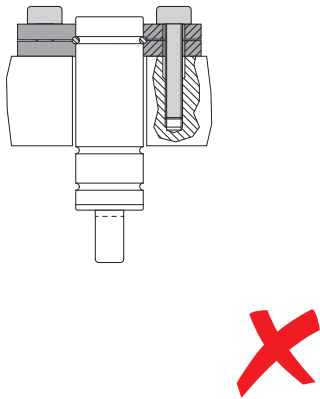
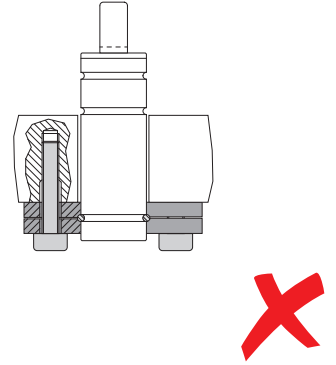
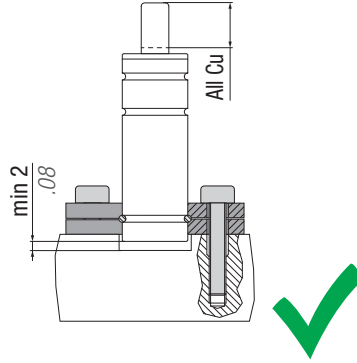
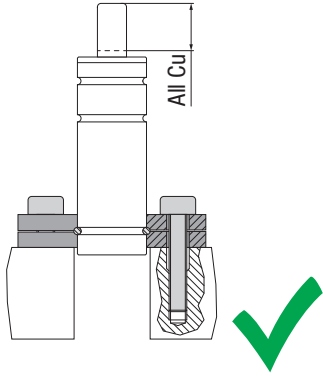

FTP

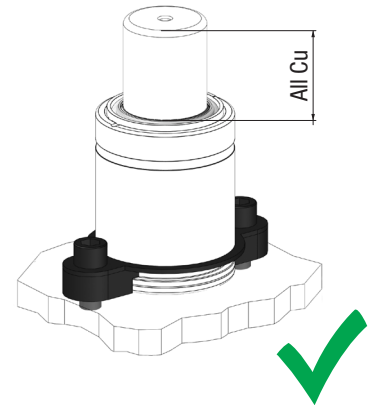

FT

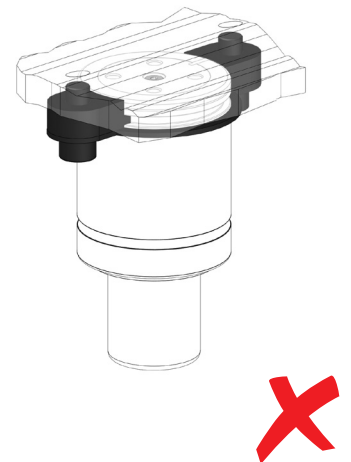
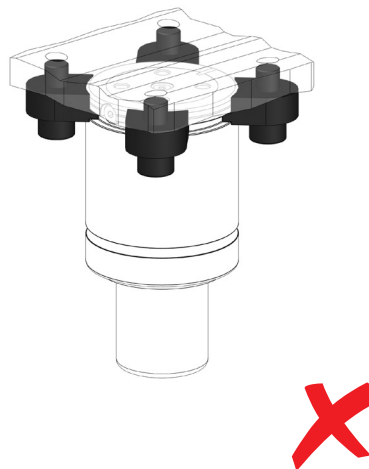
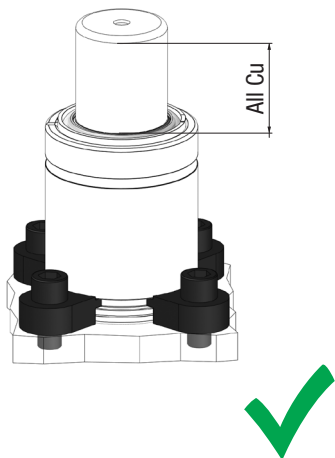

All dimensions in mm / inch

# INSTALLATION GUIDELINE - BODY MOUNT



## Installation examples

FSA - FSB - FSC - FSD - FSE

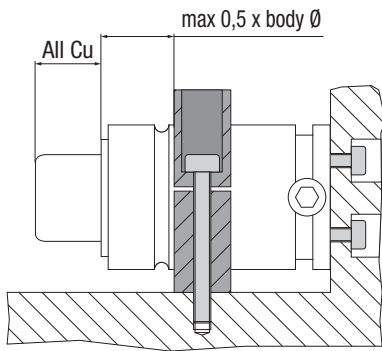

(FSA - FSB - FSC - FSD - FSE) + R

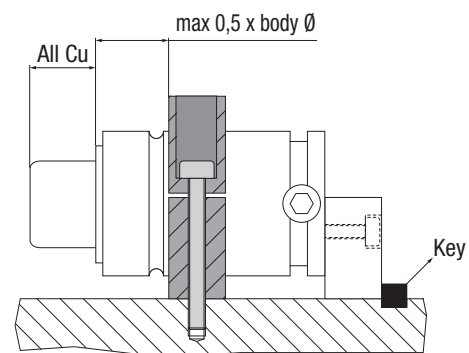
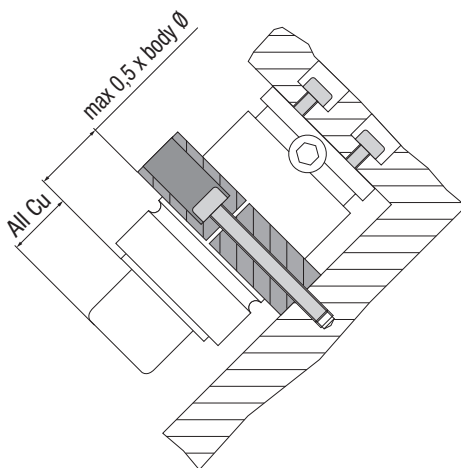
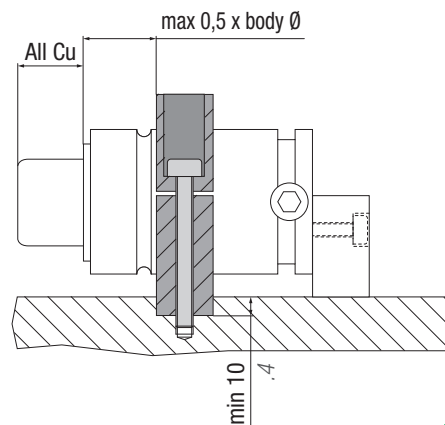
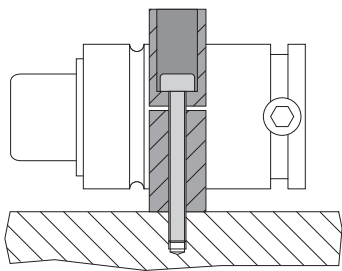
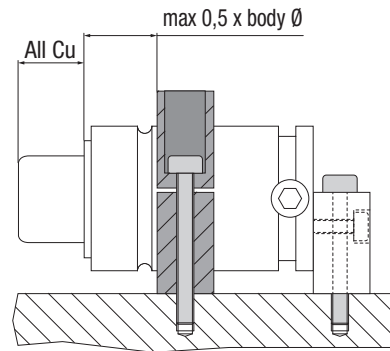

All dimensions in mm / inch

Installation examples

GM

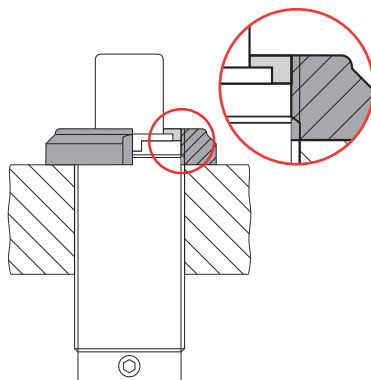
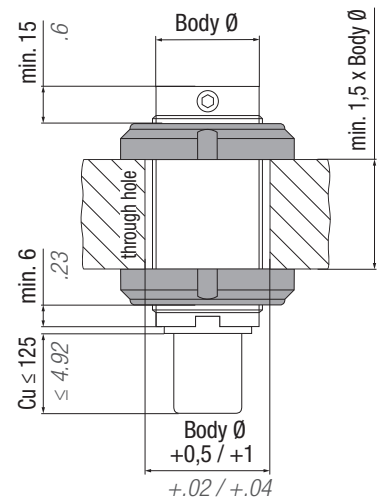
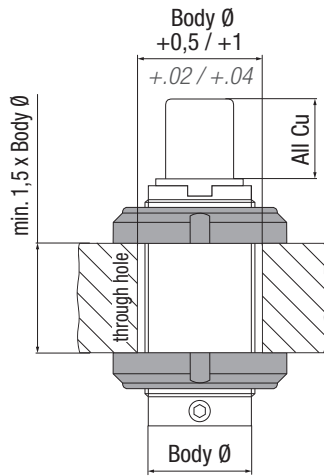
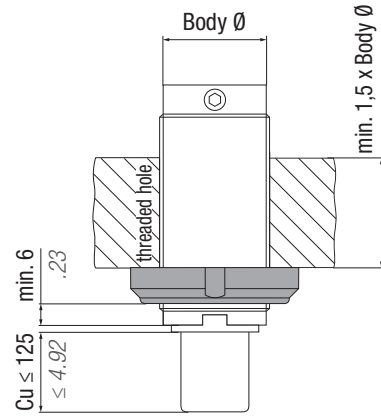
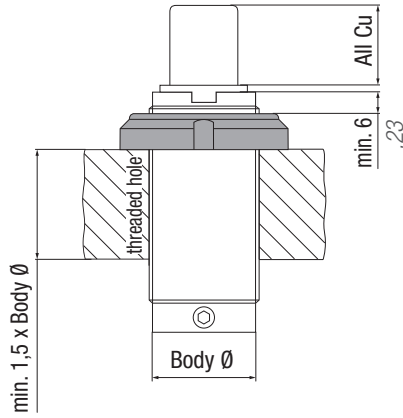

# INSTALLATION GUIDELINE - THREAD MOUNT



## Installation examples

### DM - DI

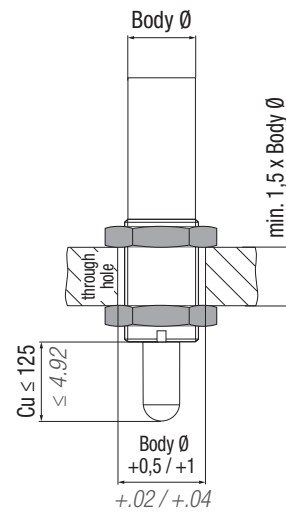
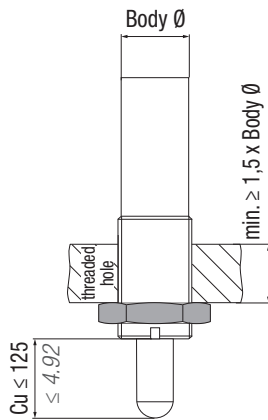
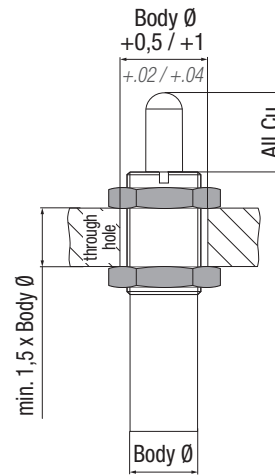
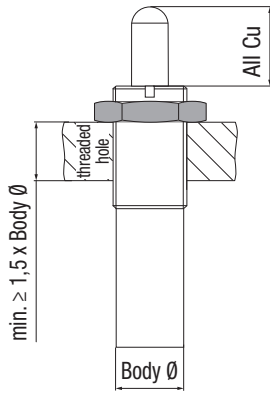

Installation examples

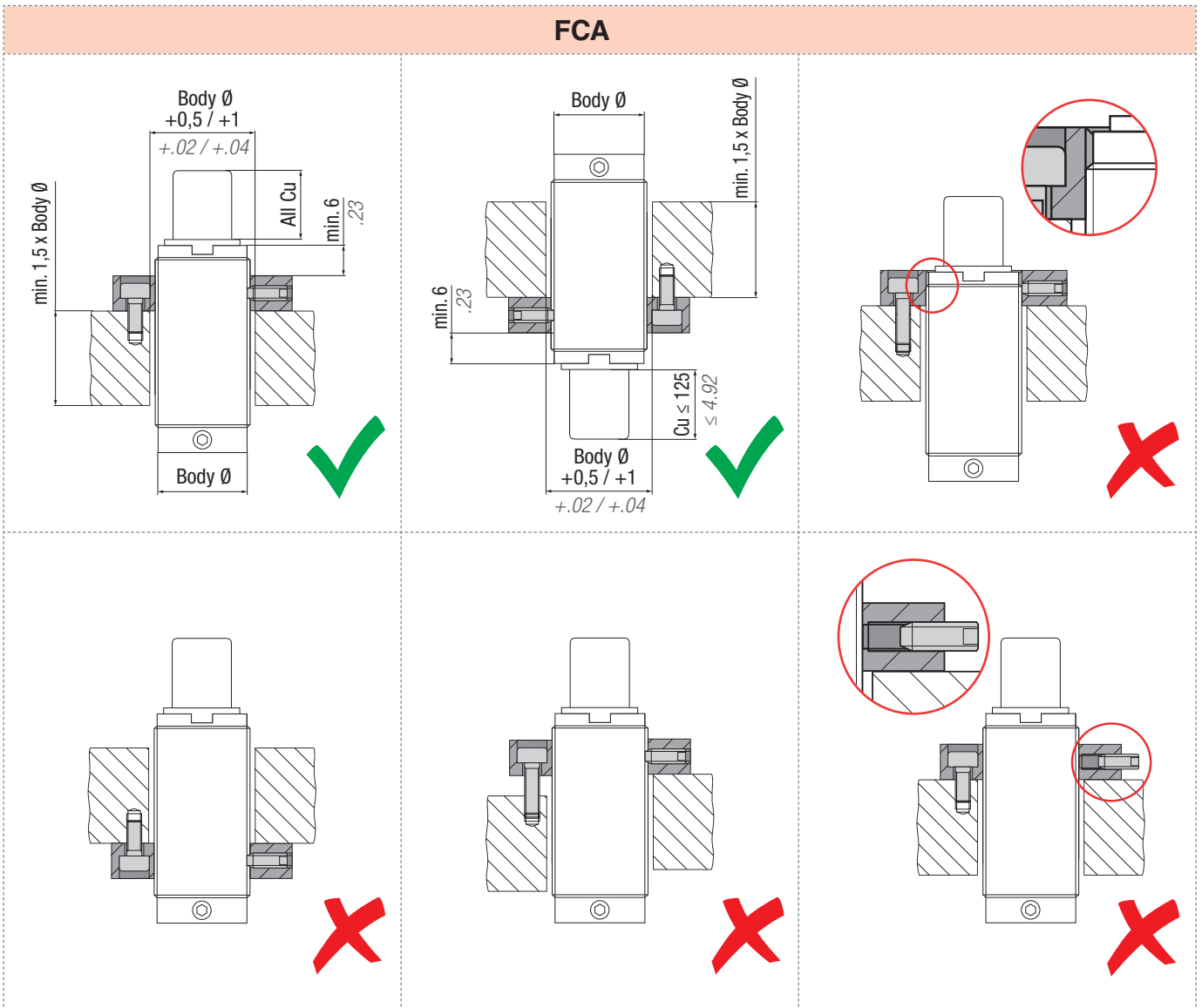

## Installation examples

**EN** Install the gas springs following the directions given here below. Detailed information is included in the specific kit.

### ML, MP, MQ series - SELF CONTAINED

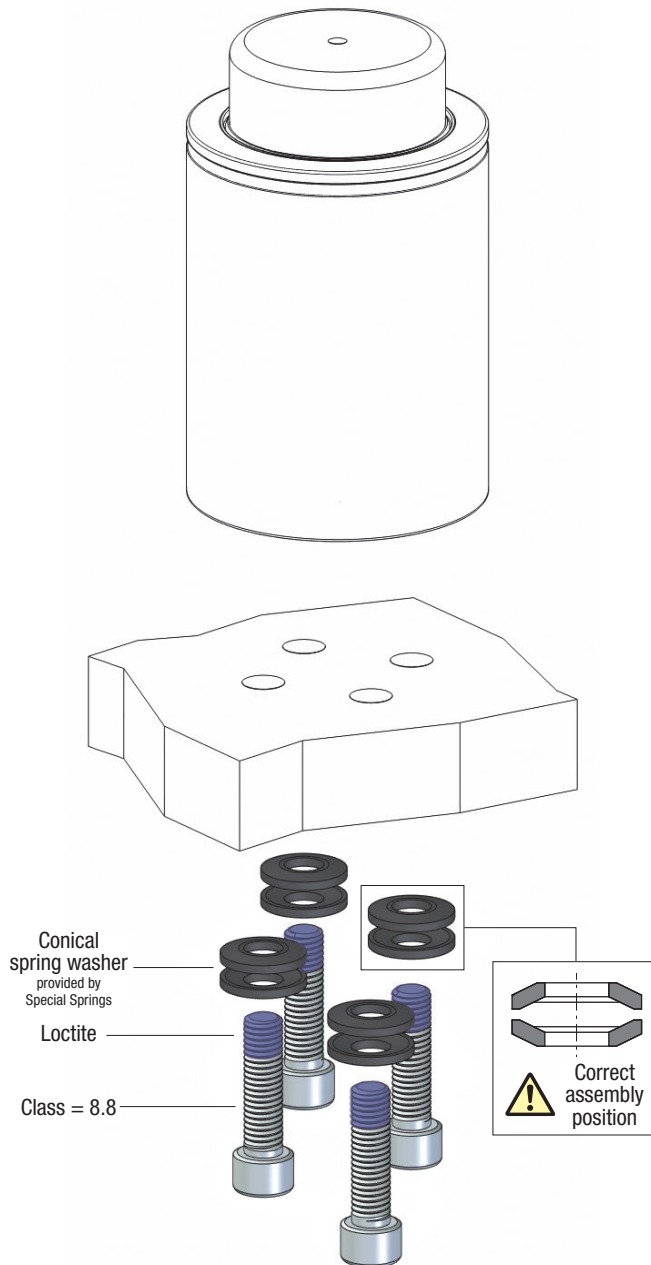

### ML - LINKABLE

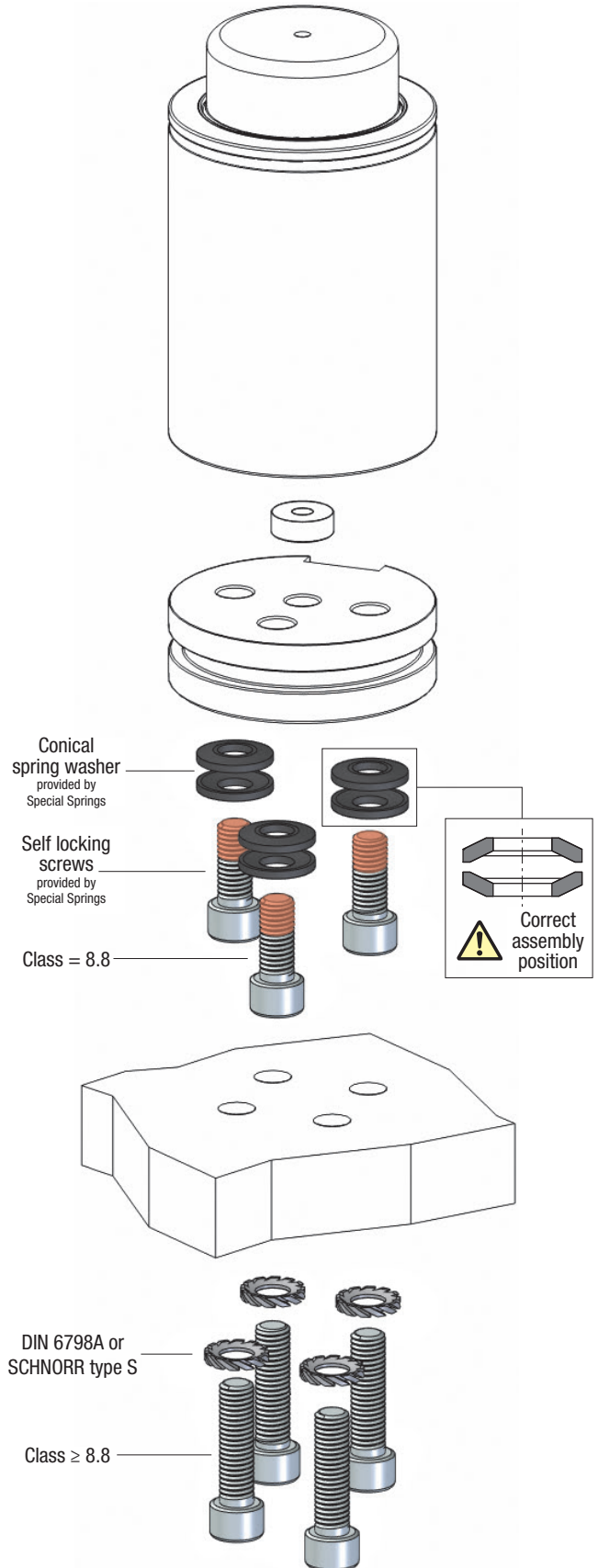



## Installation examples

### ML - EASY MANIFOLD

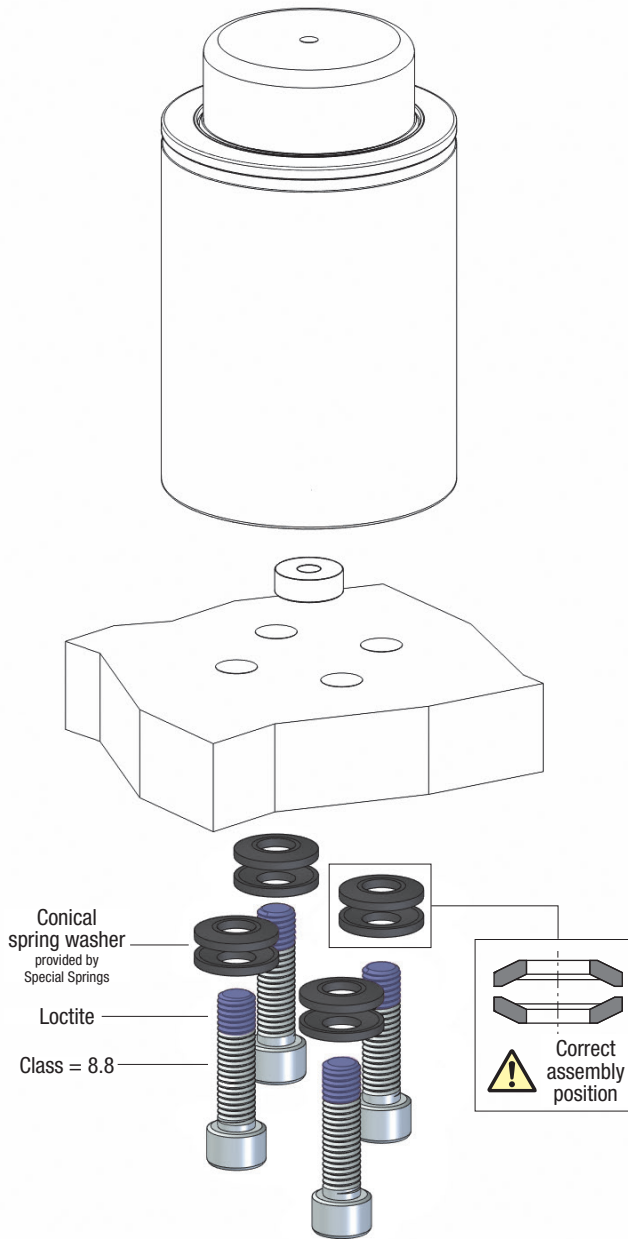

### FIXING INFORMATION

**EN** It is recommended to install gas springs in the "Self-Contained" and "Easy Manifold" versions by following the directions given here below.

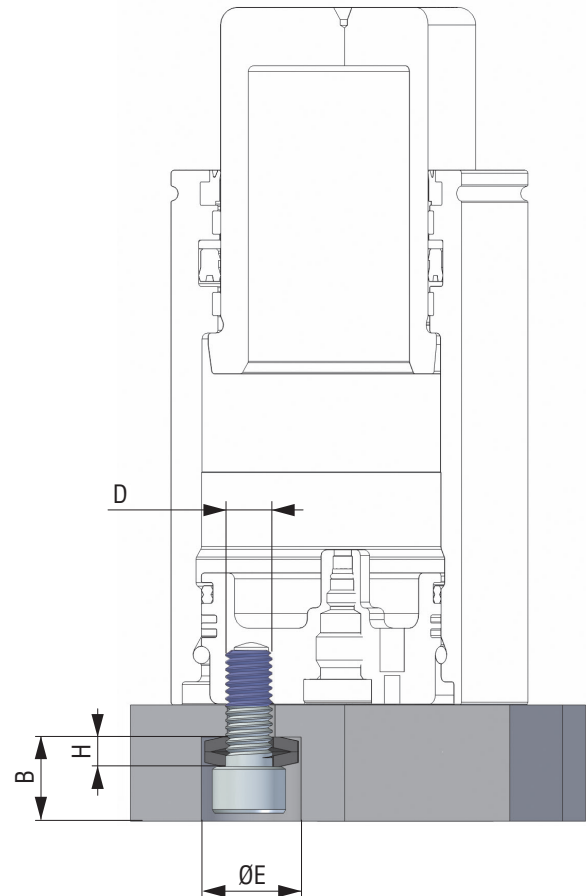

Model	Washer code	Ø E		B		H		D	
		mm	inch	mm	inch	mm	inch		
ML 1000 D	49RC06A	≥ 10,25	≥ .40	≥ 9,15	≥ .36	3,15	.12	M6	 <p>UNI EN ISO 21269:2007 class = 8.8</p>
ML 1800 D	49RC06A	≥ 10,25	≥ .40	≥ 9,15	≥ .36	3,15	.12	M6	
ML 3000 D	49RCHS08A	≥ 17,3	≥ .68	≥ 12	≥ .47	4	.16	M8	
ML 4700 D	49RC08A	≥ 18,3	≥ .72	≥ 12	≥ .47	4	.16	M8	
ML 7500 D	49RC08A	≥ 18,3	≥ .72	≥ 12	≥ .47	4	.16	M8	
ML 12000 D	49RC10A	≥ 23,3	≥ .92	≥ 15	≥ .59	5	.20	M10	

### **Headquarter**

#### **Special Springs S.r.l.**

Via Nardi, 124/A

36060 Romano d'Ezzelino (VI) - ITALY

tel. +39 0424 539181

info@specialsprings.com

www.specialsprings.com

### **North America Subsidiary**

#### **Special Springs LLC**

7707 Ronda Drive,

Canton, MI 48187 - USA

### **South America Subsidiary**

#### **Special Springs do Brasil**

Avenida Dom Pedro I, 2156 - Vila Pires

09130-012 Santo André / SP - BRASIL

### **India Subsidiary**

#### **Global Special Springs pvt. Ltd.**

Survay no. 69/2 - Chandarda, Tal. Kadi

Dist. Mehesana (Ahmedabad - Mehesana Highway)

Gujarat, 382705 - INDIA



**Sole UK Distributer**

#### ***BERGER TOOLS LTD***

Unit B1 & B2 Chaucer Business Park  
Watery Lane, Kemsing

Kent, TN15 6QY

T: +44 (0) 1732 763377

E: sales@berger-tools.co.uk

W: www.berger-tools.co.uk

Catalog code  
**9807151100019**