

Nitrogen cylinders - checking procedure of initial force F_0

Boundary condition:

- Room Temperature: $20 \pm 5 \text{ }^\circ\text{C}$
- Influence of temperature: $\pm 1^\circ\text{C} = \pm 0.33\% \text{ P}$
- Use suitable equipment, Special Springs Force Tester models FT... o IPC/DIG.
- Use calibrated load cell.
- Use a digital or analogic display connected to the load cell.
- Use equipment provided with a hydraulic jack to develop a force of 1.5 times higher than initial force developed by the cylinder you want to test.
- Place the cylinder in a safe way on a horizontal support. See the example of cylinder support:
-

Body size cylindrical support

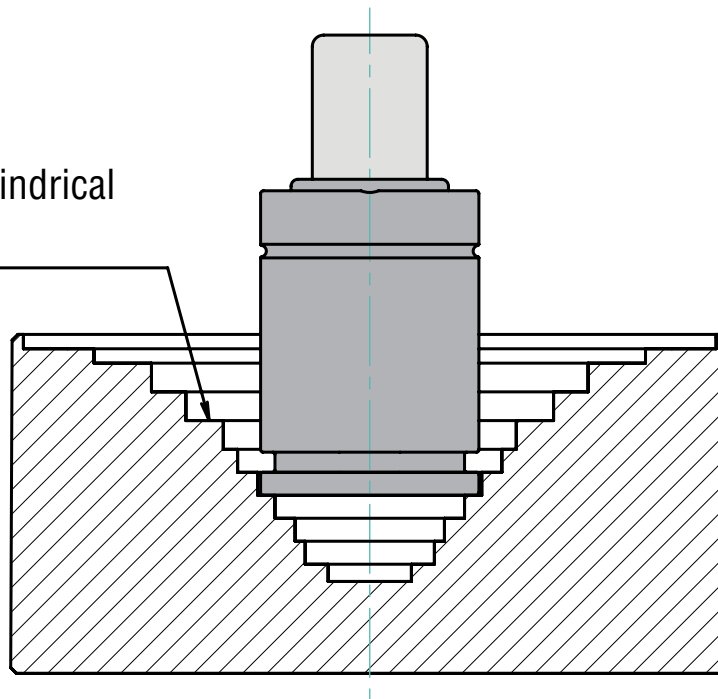

Operative testing procedure:

1. Place the cylinder in the support safely
2. Rotate the cylinder until the charging valve will be orientated on the opposite side respect of the operator
3. Bring the rod of the cylinder in contact with the load cell (the display of the visualizer will indicate few daN)
4. Compress the Cylinder rod for about 1,5 mm, release and compress again for about 1,5mm
5. Read on the display the initial force of the cylinder
6. Retract the hydraulic jack and remove the cylinder safely