

CAUFCB

GUIDE PILLAR FCA

FÜHRUNGSSÄULE FCA | COLONNA FCA

FCA 065.90.70



Material: 1.7131 Hardness: 61÷63 HRC Execution: fine ground	DAYS 12	3D-CAD	HOW TO ORDER CAUFCB * D1 * L (CAUFCB25100)
-------------------------------------------------------------------	---------	--------	-----------------------------------------------

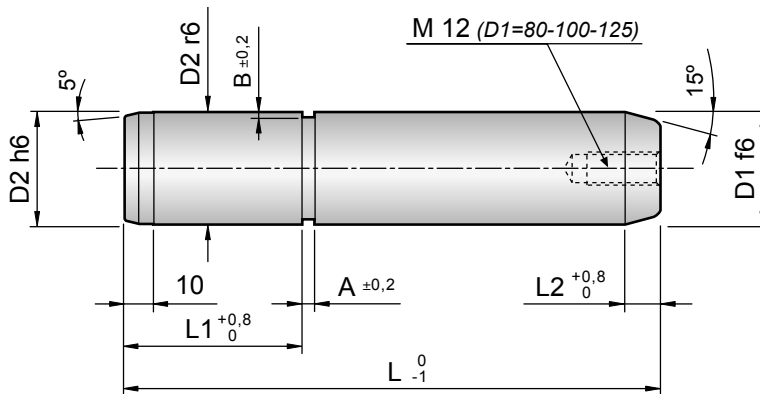

D1	D2	L1	L2	A	B	L													
						100	125	140	160	180	200	225	250	280	315	355	400	450	500
25	25	40	4	6	2,5	◇	◇	◇	◇	◇									
32	32	45	8			◇	◇	◇	◇	◇	◇								
40	40	56	10	9	3,5			◇	◇	◇	◇	◇							
50	50	70						◇	◇	◇	◇	◇	◇						
63	63	80		11	5,5					◇	◇	◇	◇	◇	◇				
80	80	100										◇	◇	◇	◇	◇	◇		
100	100	125											◇	◇	◇	◇	◇		
125	125	140	12											◇	◇	◇	◇	◇	